**User's
Manual**

YEW SERIES 80

**Model SLMC
(Style E)
Programmable Indicating
Controller
With Pulse Width Output**

IM 1B4C3-02E

Notices

■ Regarding This User's Manual

- (1) This manual should be passed on the end user. Keep at least one extra copy of the manual in a safe place.
- (2) Read this manual carefully and fully understand how to operate this product before you start operation.
- (3) This manual is intended to describe the functions of this product. Yokogawa Electric Corporation (hereinafter simply referred to as Yokogawa) does not guarantee that the functions will suit a particular purpose of the user.
- (4) Under absolutely no circumstances may the contents of this manual in part or in whole be transcribed or copied without permission.
- (5) The contents of this manual are subject to change without prior notice.
- (6) Every effort has been made to ensure accuracy in the preparation of this manual. Should any error or omissions come to your attention however, please contact your nearest Yokogawa representative or our sales office.

■ Regarding Protection, Safety, and Prohibition against Unauthorized Modification

- (1) In order to protect the product and the system controlled by it against damage and ensure its safe use, make certain that all of the instructions and precautions relating to safety contained in this manual are strictly adhered to. Yokogawa does not guarantee safety if products are not handled according to these instructions.
- (2) Be sure to use the spare parts approved by Yokogawa when replacing parts or consumables.
- (3) Modification of the product is strictly prohibited.
- (4) Reverse engineering such as the disassembly or decompilation of software is strictly prohibited.
- (5) No portion of the software supplied by Yokogawa may be transferred, exchanged, leased or sublet for use by any third party without the prior permission of Yokogawa.

■ Force Majeure

- (1) Yokogawa does not make any warranties regarding the product except those mentioned in the WARRANTY that is provided separately.
- (2) Yokogawa assumes no liability to any party for any loss or damage, direct or indirect, caused by the user or any unpredictable defect of the product.

C O N T E N T S

<u>Section</u>	<u>Title</u>	<u>Page</u>	<u>Section</u>	<u>Title</u>	<u>Page</u>
1. INTRODUCTION		1-1	5-3. Startup and Operation		5-12
1-1. Inspection		1-1	5-3-1. Manual Startup		5-12
1-2. Scope of This Manual and Associated Manuals		1-1	5-3-2. Alarm Check and Transfer to Automatic Operation		5-12
2. GENERAL		2-1	5-3-3. Normal Operation		5-12
2-1. Standard Specifications		2-1	5-4. Automatic Mode Operation		5-13
2-2. Model and Suffix Codes		2-2	5-5. Action to be Taken When FAIL or ALM Lamps Light		5-13
2-3. Options		2-3	5-5-1. Action to be Taken When the FAIL Lamp Lights		5-13
2-4. Spare Parts Supplied		2-3	5-5-2. Action to be Taken When the ALM Lamp Lights		5-13
3. INSTALLATION		3-1	5-5-3. Action to be Taken When the ALM Lamp Flashes		5-13
3-1. Wiring		3-1	5-5-4. CHECK Display		5-14
3-1-1. Wiring Precautions		3-2	5-5-5. ALARM Display		5-14
4. PRINCIPLES OF OPERATION		4-1	5-6. Operation Mode Display Lamp Flashing		5-15
4-1. Description of Circuit Operation		4-1	5-6-1. Field Operation (When SLMC is Transferred to LOCAL Operation)		5-15
4-1-1. Analog Input Circuit		4-1	5-6-2. Backup Operation		5-15
4-1-2. A/D (Analog/Digital) Converter Circuit		4-1	5-7. Connection with SPRG Programmer		5-15
4-1-3. Status Input Circuit		4-1	5-7-1. SPRG Programmer Connecting		5-15
4-1-4. Digital Computing Circuit		4-1	5-7-2. Removing the SPRG		5-15
4-1-5. Analog Output Circuit		4-1	6. MAINTENANCE		6-1
4-1-6. Status Output Circuit		4-1	6-1. Test Equipment Required for Adjustment		6-1
4-2. Principles of Computation and Control		4-1	6-2. Inspection, Calibration and Adjustment of Indicator		6-1
4-2-1. Principles of Computational Operations		4-1	6-2-1. Creating Adjustment Program		6-1
4-2-2. Configuration of Input-Output Registers		4-2	6-2-2. Adjusting Zero Point of Process Variable Indicator (Moving Coil Type)		6-1
4-2-3. Principles of Operation of Control Function		4-2	6-2-3. Adjusting Zero Point of Set Value Indicator (Moving Coil Type)		6-1
5. OPERATION		5-1	6-2-4. Adjusting Fluorescent Bar Graph Indicator		6-2
5-1. Front- and Side-Panel Features		5-1	6-2-5. Adjusting Zero Point of Control Output Indicator		6-2
5-1-1. Controller with Moving Coil Indicator		5-1	6-2-6. Inclined Mounting		6-2
5-1-2. Controller with Fluorescent Bar Graph Type Indicator		5-3	6-2-7. Adjusting Brightness of Fluorescent Bar Graph Indicator		6-2
5-1-3. Names and Functions of Tuning Panel Controls		5-4	6-2-8. Setting Sclae of Digitl Display		6-3
5-2. Preparations for Operation		5-8			
5-2-1. Check Special Parts are Installed		5-9			
5-2-2. Preparations for Operation		5-9			
5-2-3. Programs Example		5-11			

<i>Section</i>	<i>Title</i>	<i>Page</i>
6-3.	Parts Replacement	6-5
6-3-1.	Replacing Nameplate	6-5
6-3-2.	Replacing Scale	6-5
6-3-3	Replacing Fuse	6-5
6-3-4	Replacing Data Memory Backup Battery	6-5
6-3-5.	Replacing User ROM	6-6
6-3-6.	Replacing Fluorescent Tube	6-7
7.	TROUBLESHOOTING	7-1
7-1.	Troubleshooting Flowcharts.....	7-1
7-2.	Disassembling and Reassembling Procedures.....	7-9
●	Customer Maintenance Parts List	CMPL 1B4C3-03E
●	POWER SUPPLY TERMINALS for PANEL- MOUNTED INSTRUMENTS (for /HTB) IM 1B4F1-11E	

1. INTRODUCTION.

1-1. Inspection.

This instrument was thoroughly tested at the factory before shipment. However, when you receive this instrument, you should check the following:

- 1) Check for visible damage.
- 2) Check the model and suffix codes, shown on the shipping documents and also on the name plate on the rear of the instrument, and confirm that you received what you ordered.
- 3) Check that all accessories (see section 2-4) are present.

If you have any questions about this instrument, please contact either your nearest Yokogawa Sales/Service Office or Yokogawa Electric Corporation, Tokyo, Japan.

1-2. Scope of This Manual and Associated Manuals.

This Instruction Manual covers handling, operating and simple maintenance procedures for the SLMC Programmable Indicating Controller with Pulse Width Output.

The operation and functions of this controller require that it be programmed—a program flow chart must be created, a program written, and the program must be stored in SLMC ROM (Read Only Memory). (See Figure 1-2-1.)

Refer to the following manuals and materials:

STEP 1. Materials covering programming.

STEP 1 covers everything from process flow diagrams through to writing the SLMC program.

- (1) YewSeries 80 Programmable Instrument Functions and Applications – TI 1B4C2-02E.
- (2) SLMC work sheet WS 1B4C2-11.
- (3) SLMC data sheet WS 1B4C3-11E.
- (4) SLMC data sheet WS 1B4C2-14.
- (5) SLMC program sheet WS 1B4C2-15.
- (6) SLMC control function stickers.

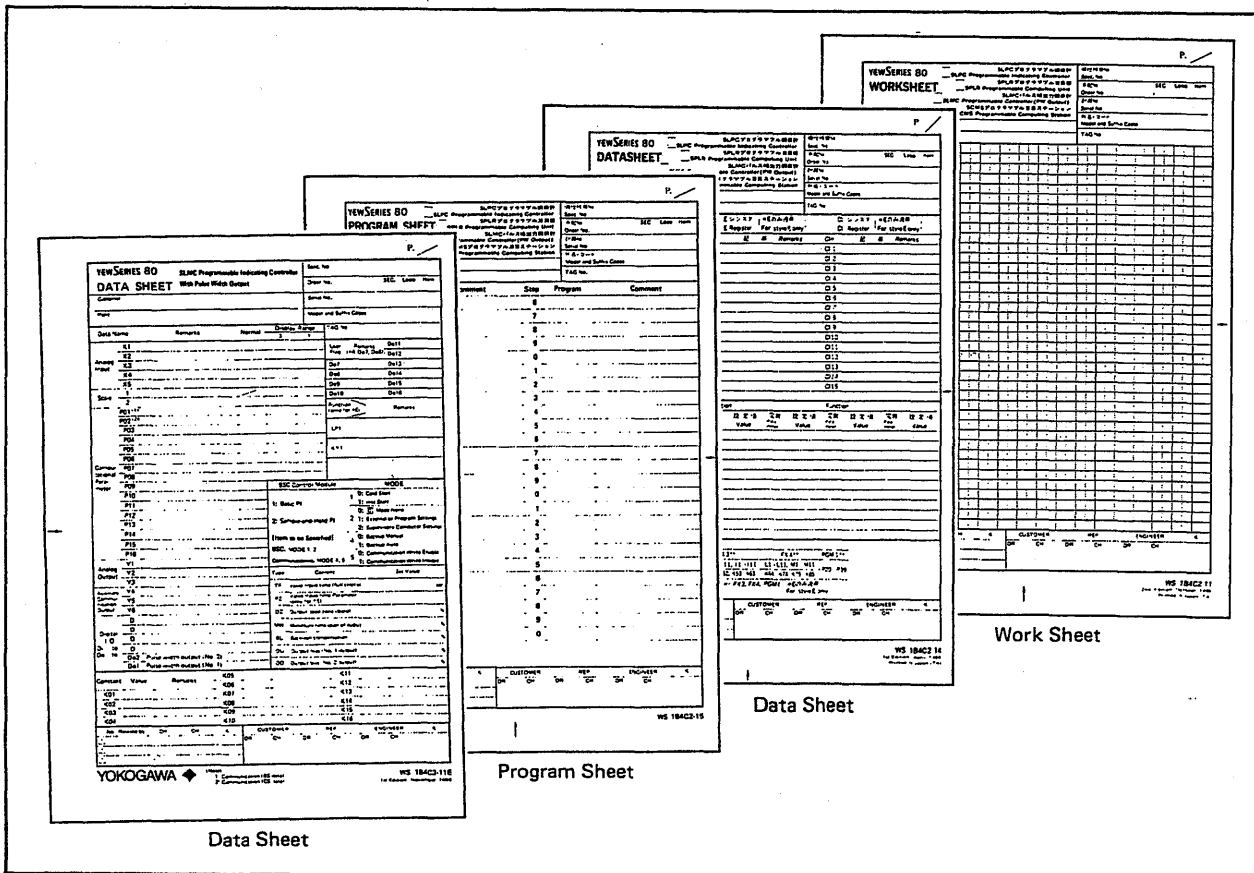

Figure 1-2-1. Sheets to be used in STEP 1.

STEP 2. Manuals covering storing programs in ROM.

- (1) SPRG Programmer Instruction Manual IM 1B4W1-02E.
- (2) Functions and Applications of SLPC Programmable Indicating Controller-SLMC Programmable Controller (PW Output) TI 1B4C2-02E.

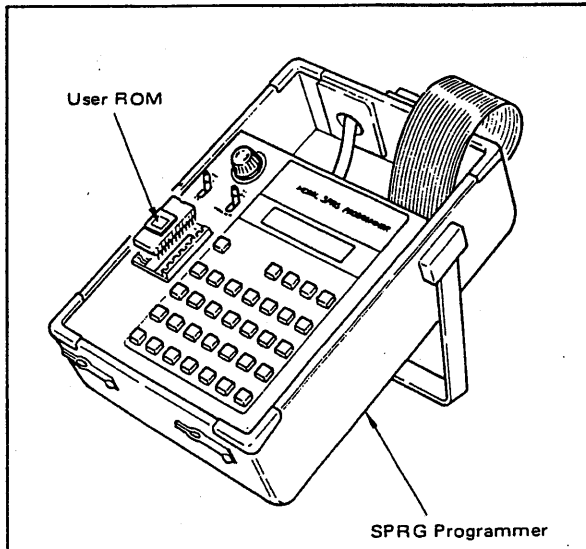

Figure 1-2-2. User ROM and SPRG Programmer

Note: When the SPRG (Style A) Programmer is used with the SLMC (Style E) Programmable Controller with pulse width output, the controller functions are limited to those of the SLMC (Style A) Controller.

STEP 3. Installation of ROM in SLMC and initiation of operation.

This step is covered by this Instruction Manual.

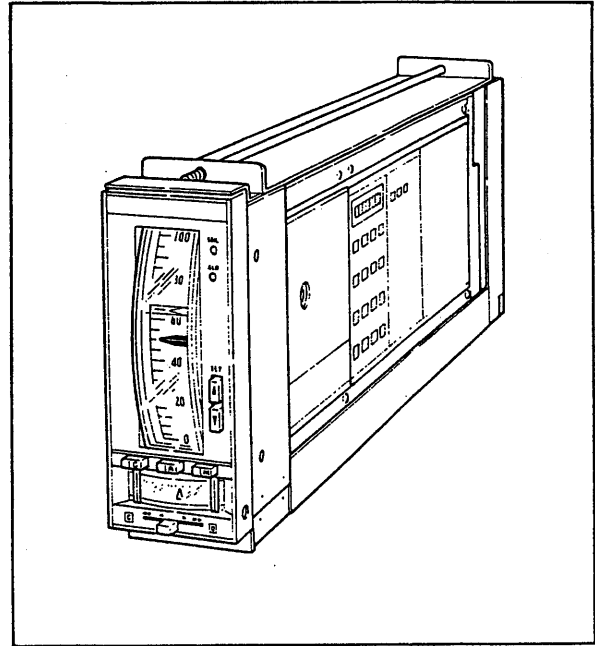

Figure 1-2-3. SLMC Programmable Controller with Pulse Width Output.

2. GENERAL.

The SLMC Programmable Controller (Pulse Width Output) is specifically designed for use in flowrate control where motor-operated valves are used as final controlling elements or in neutralizing and blending control where solenoid-operated valves are used as final controlling elements.

- Programmable to support the widest range of applications in motor- and solenoid-operated valve control.
- Permits users to develop their own programs with the ease of a handheld electronic calculator by using the SPRG Programmer.
- Incorporates a control algorithm designed to operate with final controlling elements having integrating characteristics, such as motor-operated valves.
- Communication functions allow the SLMC controller to be used with a central operator station or a computer.

2-1. Standard Specifications.

Input/Output Signals

Analog input signal: 1 to 5V DC, 5 points

Analog output signal: 1 to 5V DC, 2 points
4 to 20mA DC, 1 point

Status input signal: Contact or voltage level, 3 points

Manipulated output signal:

UP/DOWN pulse width output signal, 1 each

Status input signal:

Contact or voltage level

Status output signal:

Transistor contact

} Four points
(compatible type)

Fail output signal: Transistor contact, 1 point

Fail contact opens if the SLMC fails (open during power failure).

Indicators, Settings and Operating Functions

Process Variable & Set Point Indicators:

Moving coil meter or fluorescent bar graph display
(with four-digit display)

Output Indicator: Moving coil type

Setting method:

Manual setting: set by pushbuttons at 40 sec./full scale

Remote setting: by input signal or computation

Operation Mode Transfer:

by C/A/M switches or a user program.

Manual output operation: set by two speed lever action

Parameter Setting/Data Display:

from side tuning panel

Programmable function (PF) key:

Can be used as a status input.

PF lamp:

Turned ON and OFF by user-defined programs.

Control Functions

Control actions: PI control, sample-and-hold PI control

P (Proportional Band): 6.3 to 999.9%

I (Integral Time): 1 to 9999 seconds

Sampling Period: 0 to 9999 seconds

Sample-and-Hold PI Control Period:

0 to 9999 seconds

Control Functions Incorporated in Control Elements:

Process Variable High/Low Limit Alarm:

-6.3 to 106.3%

Velocity Alarm: 0 to 100.0%/second

Deviation Alarm: 0 to 100%

Manipulated Output Limiter (with valve opening feedback): -6.3 to 106.3%

In addition, output tracking, input compensation signal addition, nonlinear control, variable gain, feedforward signal addition, set point transmission and others are program selectable.

Pulse Width Output Setting Elements:

Valve Travel time (full stroke):

0 to 999.9 seconds

Output Dead Zone: 0 to 100%

Minimum Time Span of Output:

Settable 0 to 100% of full stroke

Output Resolution (minimum pulse width):

10 msec.

Backlash Compensation: 0 to 100%

Output Bias (No. 1 Output): 0 to 100.0%

Output Bias (No. 2 Output): 0 to -100%

Valve Opening Feedback: User-specified

Scan and Control Period: 0.2 second

Computational Functions

Category	Built-in-Functions	Max. No. of times function may be used in program
General Functions	Addition, Subtraction, Multiplication, Division, Square root,	—
	Magnitude (absolute value), Square root with "low-signal cutoff",	—
	High selector, Low selector, High limiter, Low limiter	—
		—
		—
Functions with Unit Addresses	10-line segment transfer function (equal-spaced segments)	2
	Line segment transfer function with user-definable segment spacing	2
	High limit alarms	4
	Low limit alarms	4
	First order lag	8
	First order lead	2
	Dead time, velocity computations and moving average	3 total
	Velocity limiter	6
	Timers	4
	Program set unit	1
	Detection of status change	8
Pulse input counter	4	
Logical Functions	AND, OR, XOR, NOT	—
	CMP (test if greater than or equal)	—
	Branching, Conditional branching, Subroutine calls	—
	Signal switching	—
Others	Resister (arithmetic) change	—
	Resister (arithmetic) rotation	—

Note: Where limits are indicated by a dash "—" above, this means that there is no preset limit.

Communication Functions

Can communicate with μ XL or CENTUM via Field Control Unit or Field Control Station.

Max. distance between field control unit/station and SLMC: 100 m.

Can communicate with Model SCMS programmable computing station. (can also communicate with supervisory systems)

Mounting

Mounting style: Flush panel mounting. Instruments are in housings and can be mounted either separately or side-by-side.

Inclined mounting: Instrument can be inclined up to 75° from the vertical (rear of instrument lower than front). Indicator zero may require readjustment with inclined mounting.

Connections:

Signal Wiring to/from the field:

ISO M4 (4mm) screws on terminal block.

Power and Ground Wiring:

100V version: JIS C 8303 two-pin plug with earthing contact. (IEC A5-15, UL498)

220V version: CEE 7VII (CENELEC standard) plug. Cable Length: 300mm.

JIS C8303: 125V, 15A) and 30cm cord

Housing dimensions: 182.5 (H) x 87 (W) x 480

(D: depth behind panel) (mm)

Weight:

Controller Less Housing: 3.3kg

Housing: 2kg (excluding mounting kit)

Normal Operating Conditions

Ambient Temperature: 0 to 50°C

Ambient Humidity: 5 to 90% relative humidity (non- condensing).

Power Supply: Two versions, for "100V" (standard) or "220V" (option/A2ER). Both versions may use AC or DC, without change to the instrument:

Version	100V	220V
DC (polarity reversible)	20 to 130V	120 to 340V
AC (47 to 63Hz)	80 to 138V	138 to 264V

2-2. Model and Suffix Codes.

Model	Suffix codes	Style	Option codes	Description
SLMC	Programmable Indicating Controller with Pulse Width Output
Indicator	-1	Moving coil type
	-2	Fluorescent bar graph type*2
	4	Enhanced model
	0	Always 0
Style code		*E	Style E
Options			/NPR /UPR	Unprogrammed With user program
Common options			/A2ER	220V power supply*1
			/MTS	With mounting kit
			/SCF	Bezel color change
			-G□M /NHS /NPE	Without housing Nameplate engraving

*1 Specify /A2/NHS to order without housing.

*2 The order acceptance of fluorescent bar graph is discontinued.

2-3. Options.

/NPR: Controller supplied unprogrammed (with blank EP ROM). The user can write a program into ROM using the SPGR Programmer.

/UPR: Controller supplied with user program. The SLMC controller is supplied with a ROM on which user-specified functions are written.

/A2ER: For "220V version" power supply.

/MTS: Controller supplied with kit for lone mounting.

/SCF-G□M: Mounting kit bezel color change from standard color (black). Choose color from set of optional colors (see GS 22D1F1-E). Specify color code in the box □.

/NHS: No housing, instrument only. See GS 1B4F1-E to order housing separately.

/NPE: Engraved front-panel nameplate.

2-4. Spare Parts Supplied.

Fuse: 1A, one.

ROM: one. (blank ROM (part No. G9003LT) is installed when "/NPR" is specified.)

Note: The fuse (S9510VK) is the dedicated fuse, Do not use it for other products.

3. INSTALLATION.

For general precautions regarding installation of this instrument, refer to the instruction manual "Installation of Panel-Mounting Instruments" (IM 1B4F1-01E).

3-1. Wiring.

The external signal connections for the SLMC Programmable Controller (PW Output) are made on the terminal board located on the rear of the controller housing. Remove the terminal board cover and connect external signal wires to the M4 size screw terminals. After completing the wiring, be sure to replace the cover. (See Figures 3-1-1 and 3-1-2.)

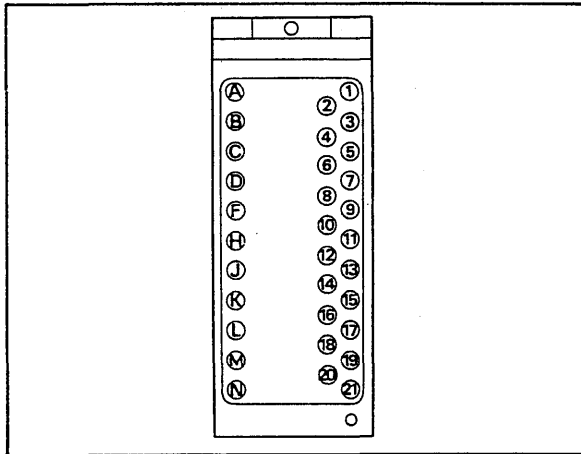

Figure 3-1-1. Terminal Layout.

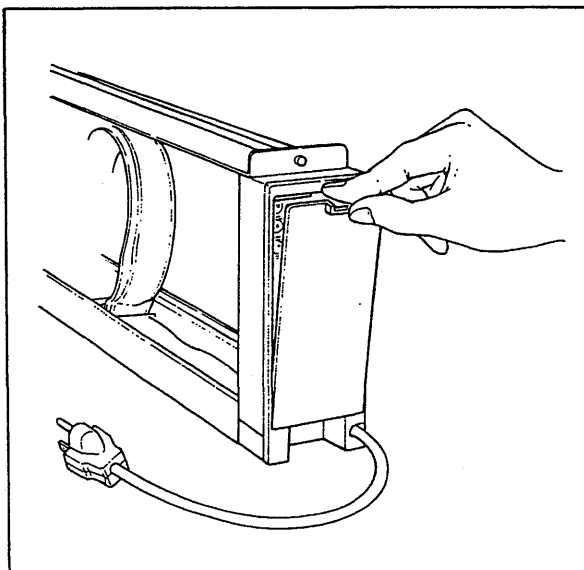

Figure 3-1-2. Terminal Cover.

Table 3-1-1 shows the terminal designations and signals to be connected.

● Terminal Connections

Table 3-1-1. Terminal Connections.

Terminal Designation	Description	Terminal Designation	Description
1	+ > Analog input 1	17	+ > Communications (*1)
2	- > Analog input 2	18	- > Status signal 4 (IN4, OUT3)
3	+ > Analog input 3	19	+ > Fail (negative terminal)
4	- > Analog input 4	20	- > Analog output 1 (*2)
5	+ > Analog input 5	21	- > current output)
6	- > Status signal 1 (IN1, OUT6)	A	+ > Analog output 2
7	+ > Status signal 2 (IN2, OUT5)	B	- > Analog output 3
8	- > Status signal 3 (IN3, OUT4)	C	+ > Manipulated output No.1
9	+ > Status signal 4 (IN4, OUT3)	D	- > Manipulated output No.2
10	- > Fail (negative terminal)	F	+ > Fail (positive terminal)
11	+ > Analog output 1 (*2)	H	- > Fail (positive terminal)
12	- > current output)	J	+ > Fail (positive terminal)
13	+ > Analog output 2	K	- > Fail (positive terminal)
14	- > Analog output 3	L	+ > Fail (positive terminal)
15	+ > Manipulated output No.1	M	- > Fail (positive terminal)
16	- > Manipulated output No.2	N	+ > Fail (positive terminal)

Notes

- *1: Use shielded twisted-pair cable (SCCD, see GS 34B6T1-01E).
- *2: A jumper is connected between terminals 6 and 8. If terminals A and B are not used, use the jumper to connect them together.

3-1-1. Wiring Precautions.

- (1) Be sure to terminate all cable connections in solderless crimp-on lugs.
- (2) Each status input contact and voltage input must be as per SLMC specifications. Note the limits on lead-wire resistance, voltage drop in lead-wires, and voltage (high/low) levels. (Refer to the SLMC General Specification at the back of this manual).
- (3) The fail and digital outputs are transistor contact signals, (isolated from power supply and other internal circuitry). When connecting external devices, pay attention to the following: (See Figure 3-1-3.)
 - Observe correct polarity of contact output terminals.

- When connecting a relay or other such inductive device, connect a surge absorber (protective diode – Figure 3-1-3, CR circuit, etc.) in parallel with the load.
 - Note that contact outputs cannot be connected directly to an AC circuit. Use a relay to switch an AC circuit (see Figure 3-1-3).
 - Do not connect any load which exceeds the contact rating. (Max. 30V DC, 200mA).
- (4) Status I/O signals are specified by a program. If these are not specified, status signals 1 through 3 are used as DIs (inputs) and status signal 4 as a DO (output).
 - (5) Use shielded twisted-pair SCCD cable for communication lines (terminals 17, 18).
 - (6) Short-circuit unused current output terminals.

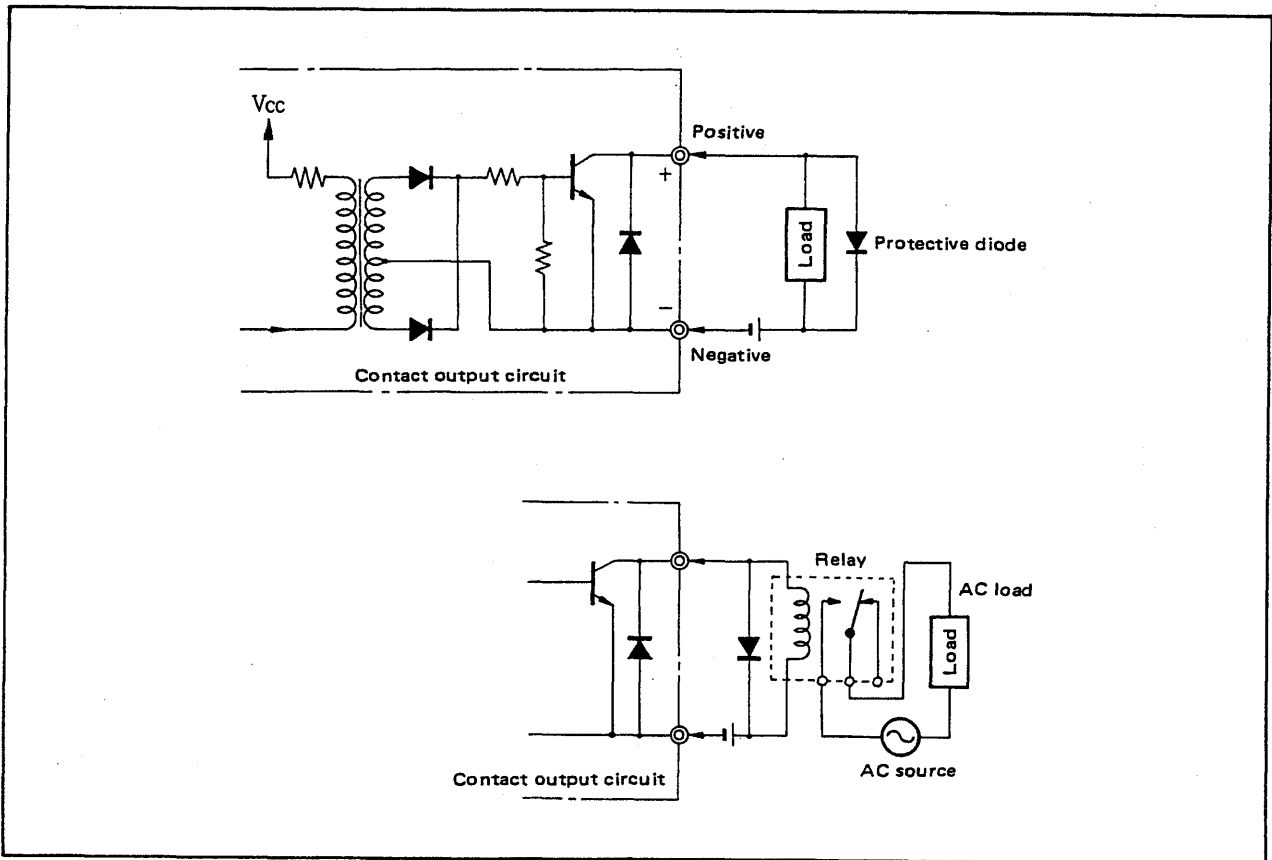

Figure 3-1-3. Connection of Contact Outputs.

4. PRINCIPLES OF OPERATION.

4-1. Description of Circuit Operation.

Refer to the SLMC circuit block diagram in page 4-4 below.

4-1-1. Analog Input Circuit.

A voltage input signal enters the input circuit comprising R_{IN} , R_1 and C_1 . R_{IN} resistance is high (1 M ohm), so it normally does not affect circuit operation. If the input circuit is open (input disconnected), however, it provides a DC path between (+) and (-) input terminals to prevent the buildup of static charge on the (+) input line. 0V DC input (e.g. input open) is equivalent to -25% of range.

R_1 and C_1 from an input filter of time constant approximately 0.1 sec.

All analog-input negative leads are connected to a common line inside the SLMC.

4-1-2. A/D (Analog/Digital) Converter Circuit.

Analog input signals entering the input circuit are selected in turn by the input multiplexer. The comparator compares an input signal with the output of the D/A (digital/analog) converter circuit, and the CPU adjusts the D/A converter output so that the two signals are equal — basically a successive-approximation type A/D converter. The corresponding digital value is stored in the data memory (RAM).

4-1-3. Status Input Circuit.

Status input signals are isolated by a transformer in the input circuit. Input status is read via an input port and transmitted via the data bus to RAM (when it is specified as an input by a program.)

At the same time as the status inputs are read, the status of switches (SET, C/A/M, MV, TUNING, ACTION) on the instrument front and side panels is also read and stored in RAM.

4-1-4. Digital Computing Circuit.

When all the input data are read, the microprocessor (CPU) performs data processing according to the computation/control program stored in user ROM.

The results of computation and control are output via the D/A circuit or output ports.

If a supervisory system is connected, data communications is performed via an LCS card. The communications line is isolated from the controller by a photocoupler.

The WDT (watch dog timer) connected to the CPU supervises the CPU operation — it causes the FAIL lamp to light and outputs a fail contact signal if the CPU fails. In such a case, the manipulated output current signal (Y1) is automatically isolated from the digital circuit, and can be varied manually. The process variable indicator then automatically displays the value of input signal No. 1 (X1).

4-1-5. Analog Output Circuit.

The analog output signals, after D/A conversion, are fed via the output multiplexer and buffer amplifier to the current and voltage output circuits.

The analog output signal negative line is common, and is connected directly to the analog input signal common negative line.

4-1-6. Status Output Circuit.

Status signals from the output ports are transformer-isolated, and are output to the field as open-collector contact signals (when they are specified as outputs by a user program).

4-2. Principles of Computation and Control.

4-2-1. Principles of Computational Operations.

The SLMC performs three basic operations — reading the input signal, computation, and outputting the computed result. The example in Figure 4-2-1 shows how the addition of two input signals is programmed, and Figure 4-2-2 shows how the stack registers change during the program. Computations are performed in the common stack registers S. Connection of signals to the registers — that is, inputting to the S registers — is performed by means of the LOAD (LD) instruction. The S registers S_1 thru S_5 comprise a "stack", and data in S is pushed down (S_1 to S_2 , etc.) each time data is input by the LD instruction.

Arithmetical operations can be performed on the data thus input by using FUNCTION instruction. There are 37 kinds of computational and control FUNCTION instructions, and these instructions are written using a corresponding mnemonic symbol, such as +, ÷, HSL, etc. The computation is performed on data stored in the S registers, and the result is popped up to the top register, S_1 .

The STORE (ST) instruction is used for copying a computed result from the top register of stack to an output register. The contents of the S registers are not changed by an ST instruction.

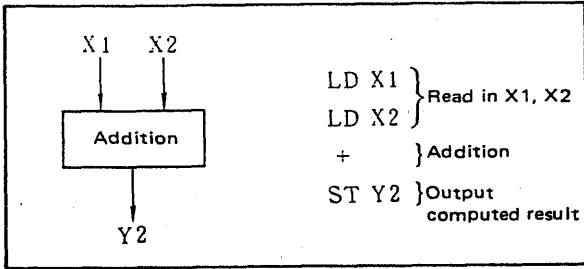

Figure 4-2-1. Two-input Arithmetic Unit and Program.

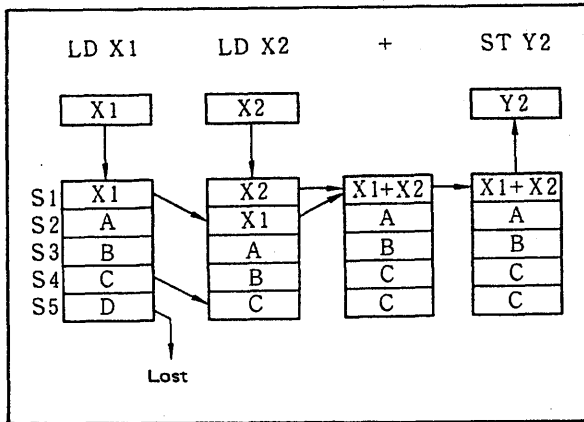

Figure 4-2-2. Program and Effect on Arithmetic Registers.

4-2-2. Configuration of Input-Output Registers.

Figure 4-2-3 shows the SLMC register configuration. Analog, digital and set parameter inputs are read into the registers X_N , DI_N and PN before execution of the user program begins. The user program reads necessary input signals and parameters from the respective input registers into the arithmetic registers using LD instructions, and copies the computed results to the output registers (DO_N , Y_N) using ST instructions. Finally, the controller outputs the contents of the output registers (DO_N , Y_N) as analog or digital values.

This cycle repeats every 0.2 sec.

4-2-3. Principles of Operation of Control Function.

The SLMC control function module BSC computes deviation between the setting value SV and the process variable PV and outputs the PI-computation result as pulse-width manipulated outputs DO_1 and DO_2 .

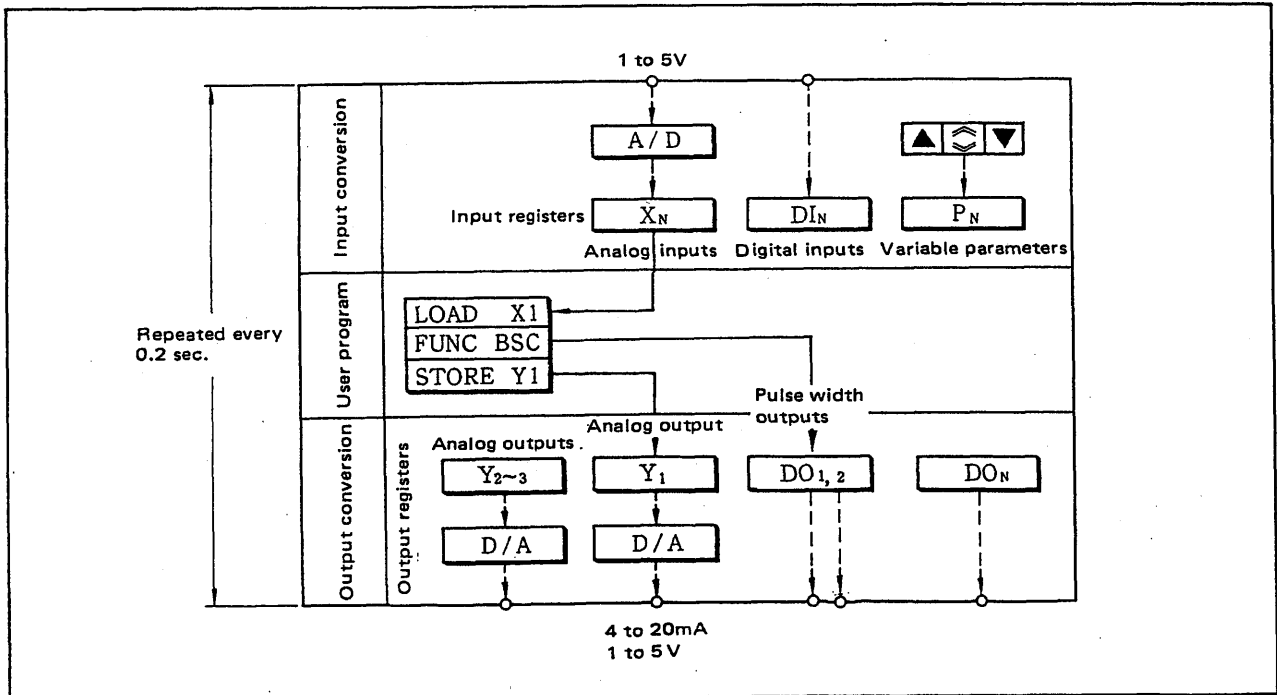

Figure 4-2-3. Configuration of Input-Output Registers.

The program for operating the SLMC as a PI controller is as simple as shown below.

(Program step) (Instruction)

1. LD X1
2. BSC
3. ST Y1 (for feedback signal indication)
4. END

BSC incorporates not only simple functions such as shown above, but also a number of complex functions as shown in Figure 4-2-4. These functions can be utilized by using the An and FLn registers in the program.

For example, if a cascade set value input is needed, connect the cascade set value input to A1 by using an ST instruction; if feedforward compensation is needed, the feedforward signal must be connected to A4. If the input high/low alarm status must be output, the contents of FL1 or 2 must be connected to digital output registers DO_N.

The registers An, Bn and FLn are initialized so that they will have no effect unless they are used. Additional control algorithms are provided as controller functions which may be used in a program. The control element functions include standard PI and sample-and-hold PI.

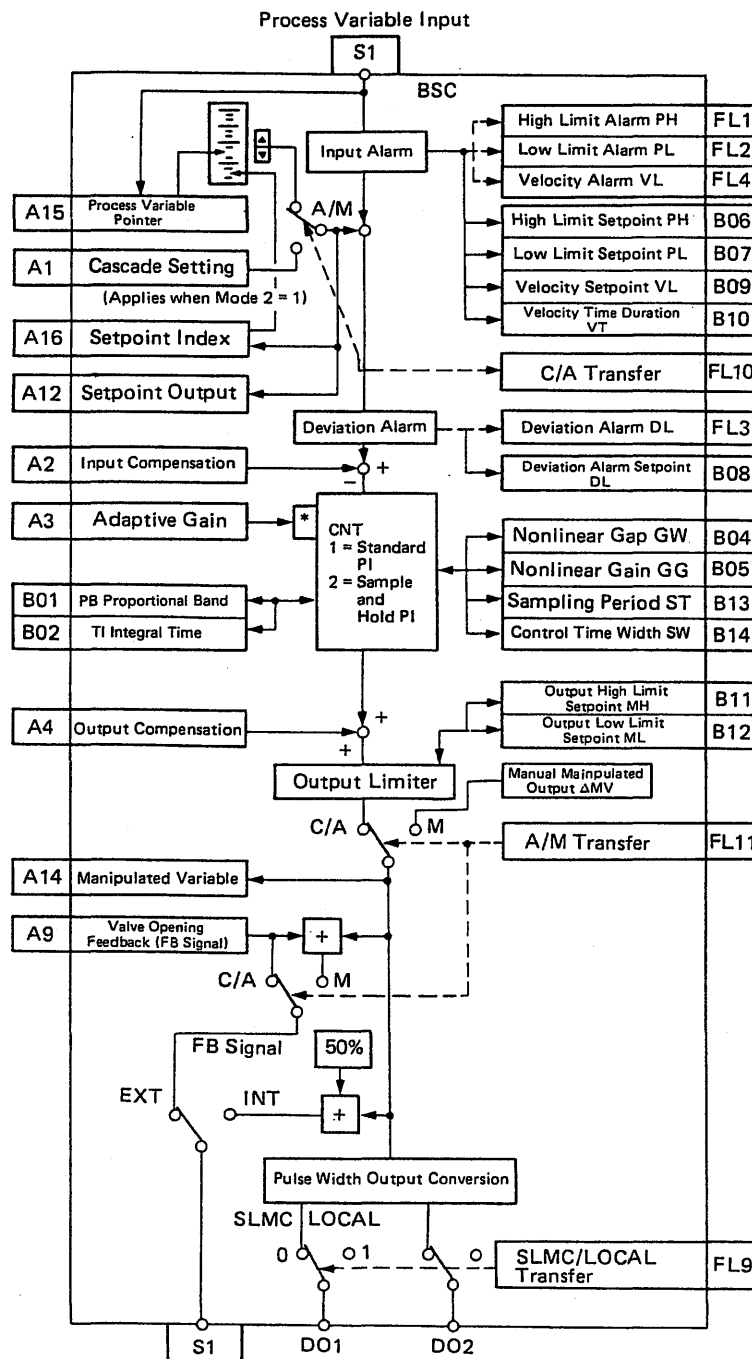
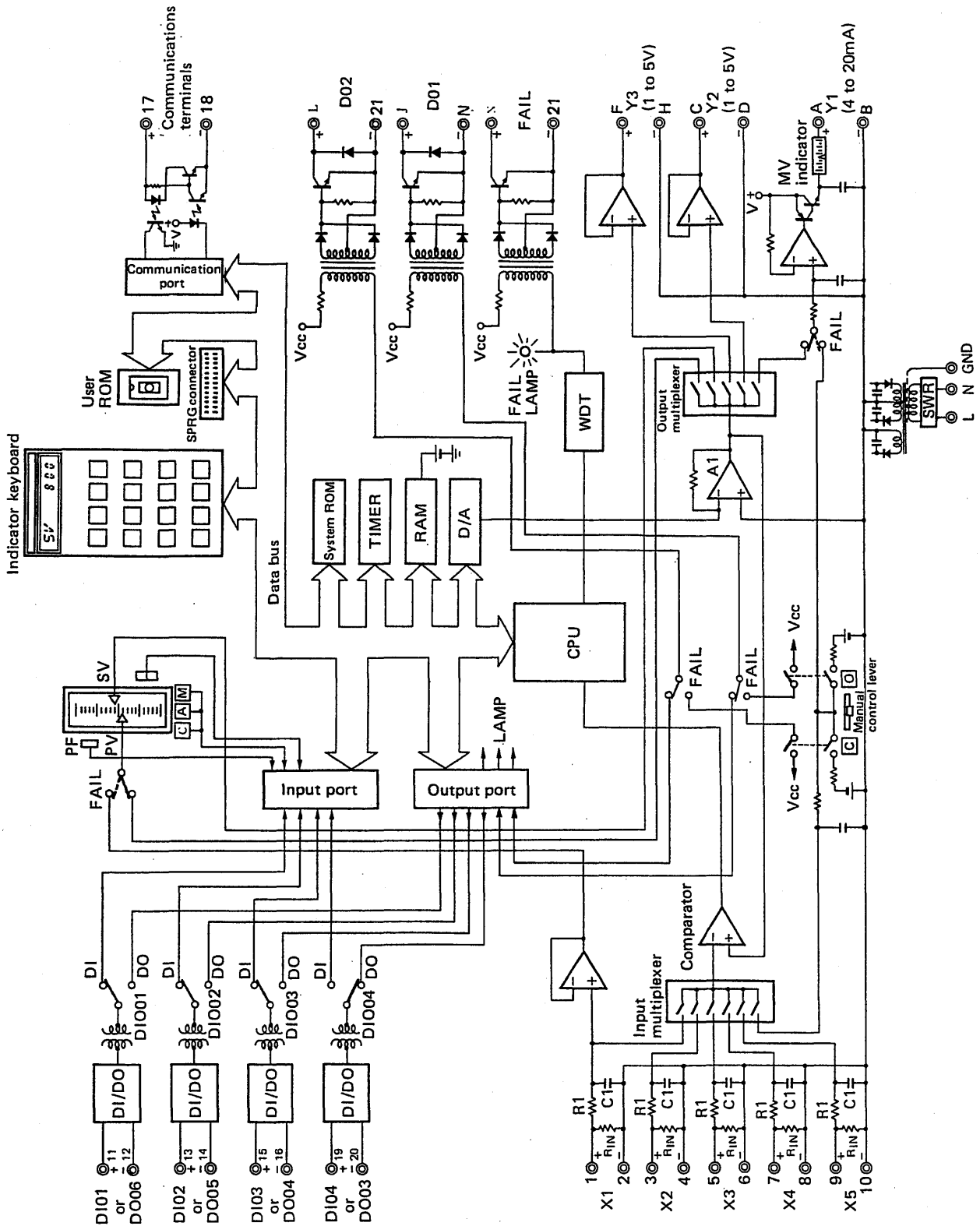

Figure 4-2-4. BSC Function Block for SLMC.

■ SLMC circuit block diagram



5. OPERATION.

5-1. Front- and Side-Panel Features.

5-1-1. Controller with Moving Coil Indicator.

This controller uses a moving coil type indicator for indicating the process variable and set value (set point). Figure 5-5-1 shows the front view of this type of controller (SLMC-140*E), and Figure 5-1-2 shows the side view. The names of panel controls etc. are also shown in these figures.

- (1) FAIL lamp.
Lights if the controller fails.
- (2) ALM lamp.
Lights to indicate alarm status, and flashes when data backup battery voltage drops.
- (3) Process variable pointer.
Displays the BSC function process variable.
- (4) Set value pointer.
Indicates the set value of the controller.

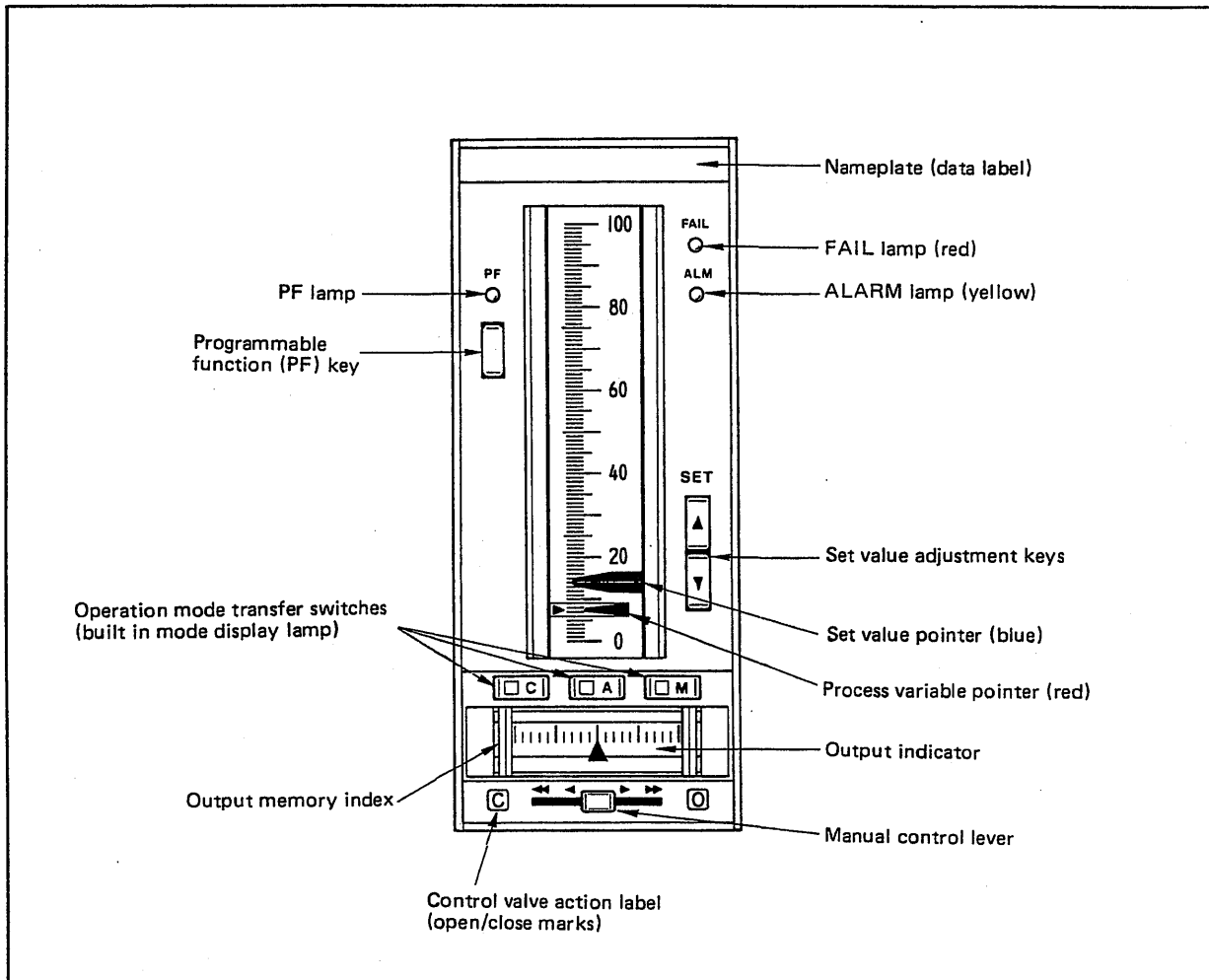

Figure 5-1-1. SLMC Front View.

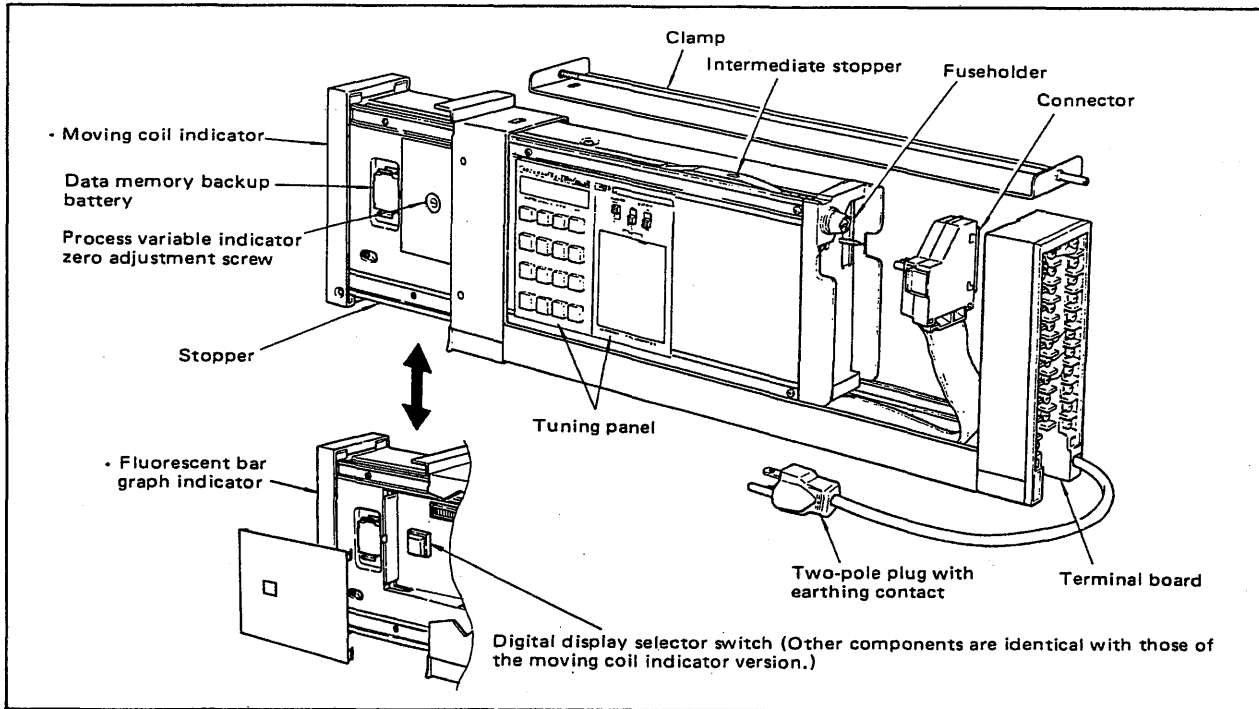

Figure 5-1-2. Side View of Instrument.

- (5) Set value adjustment keys.
Used for adjusting the set value of BSC function. It may be adjusted in A (auto) or M (manual) modes.

Setting:

- ▲ The set value increases when the key is pressed.
- ▼ The set value decreases when the key is pressed. (If both keys are pressed, the set value remains unchanged.)

Rate of change: 40 sec./full scale.

Fine adjustment:

Momentarily depressing the key (for approx. 0.2 sec.) changes the set value by 0.1%.

- (6) C/A/M operation mode transfer switch.
The desired operation mode can be selected by pressing the relevant pushbutton.

Mode C:

Automatic control. The set value is set using the computational functions, or by communications data.

Mode A:

Automatic control. The set value is set by SET keys.

Mode M:

Manual operation. The control output signal can be increased or decreased using the manual control lever. The set value can also be adjusted.

- (7) Output indicator.
Output indicator is independent of control functions.
Data stored into the register S1 can be indicated by the output indicator using an ST Y1 com-

mand. The contents of the S1 register are described with the feedback signal and operation mode (see the table below).

Data Stored into S1 Register after Executing BSC.

Signal Operation mode		With feedback signal	Without feedback signal
		C or A	Feedback signal
M	Operating	Manual control output (ΔMV) + feedback signal	Manual control output (ΔMV) + 50% output
	Pulse output completed	Feedback signal	50% output

- (8) Manual control lever

Used for adjusting the manipulated output signal of the control function module BSC in manual (M) mode (with selected direct action). (See p. 5-6, item (4)).

Action: Moving this lever to the left turns on valve operating output 2.
Moving this lever to the right turns on valve operating output 1.

Setting rate: ◀, ▶ pushbuttons, 40 seconds/full scale

◀◀, ▶▶ pushbuttons, 4 seconds/full scale

- (9) Programmable function (PF) key
When the PF key is pressed for about 0.2 seconds, it works as a status input (if the PF key is defined by a user program).
- (10) PF lamp
Can be turned on and off by a user-defined program.

5-1-2. Controller with Fluorescent Bar Graph Type Indicator.

This controller uses a fluorescent bar graph type indicator for indicating the process variable value and set value. Figure 5-1-3 shows the front view of this type of controller (SLMC-240*E). The names of panel controls etc. are also shown. For a side view of the instrument, see Figure 5-1-2.

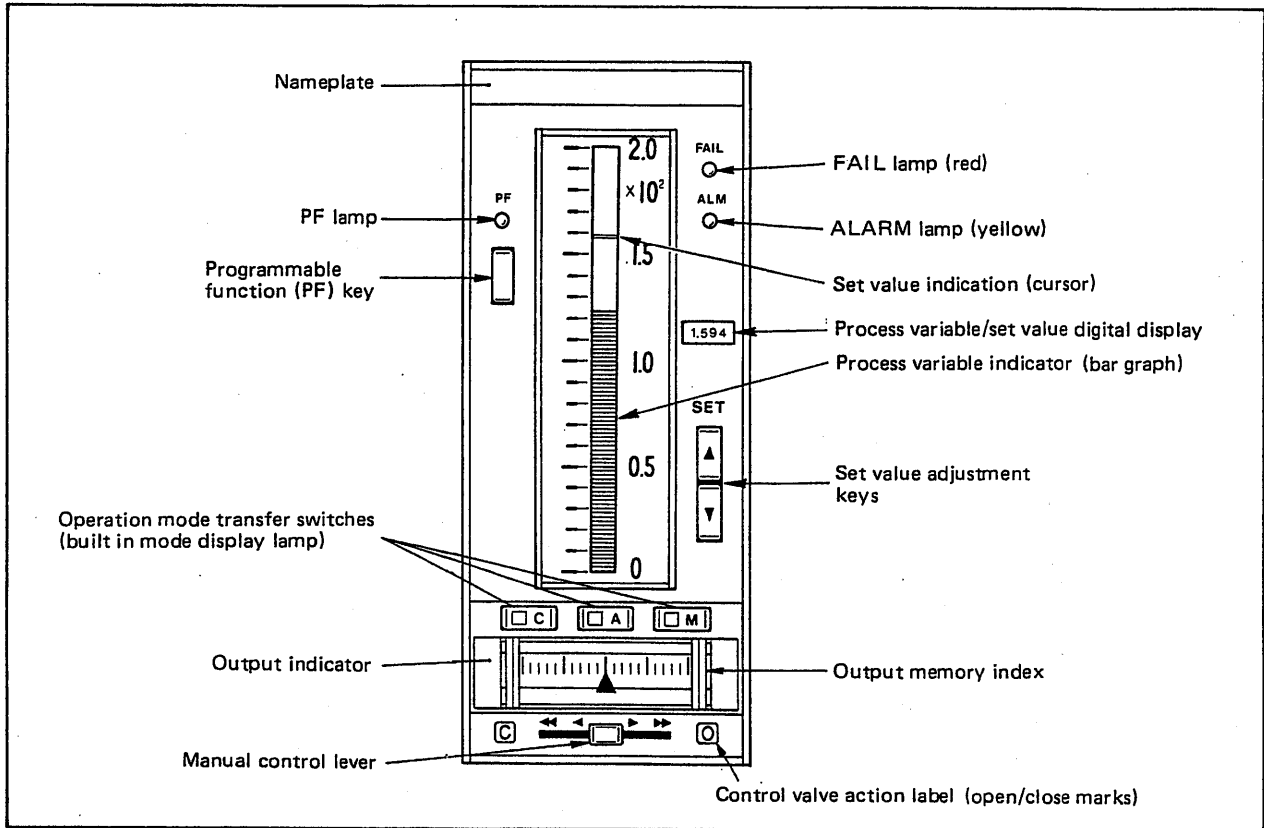

Figure 5-1-3. Front View of the Instrument.

- (1) Process variable bar graph indicator
Displays the BSC function module process variable on a bar graph indicator.
- (2) Setting value indicating cursor
Displays the BSC function module setpoint with a high-intensity cursor.
- (3) Process variable/setpoint digital display
Displays the BSC function module process variable in engineering units (4-digit display). The setpoint is displayed as long as the display selector pushbutton on the side panel is held pressed (refer to Figure 5-1-4).
The other functions are the same as those in section 5-1-1.

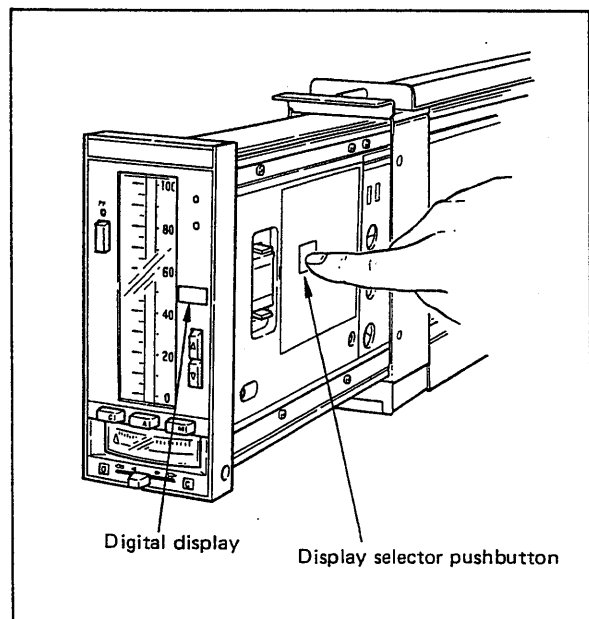

Figure 5-1-4. Display Selector for Digital Display.

5-1-3. Names and Functions of Tuning Panel Controls.

■ Panel Configuration.

The tuning panel for parameter setting and data display is on the right side of the SLMC controller. (See Figure 5-1-5).

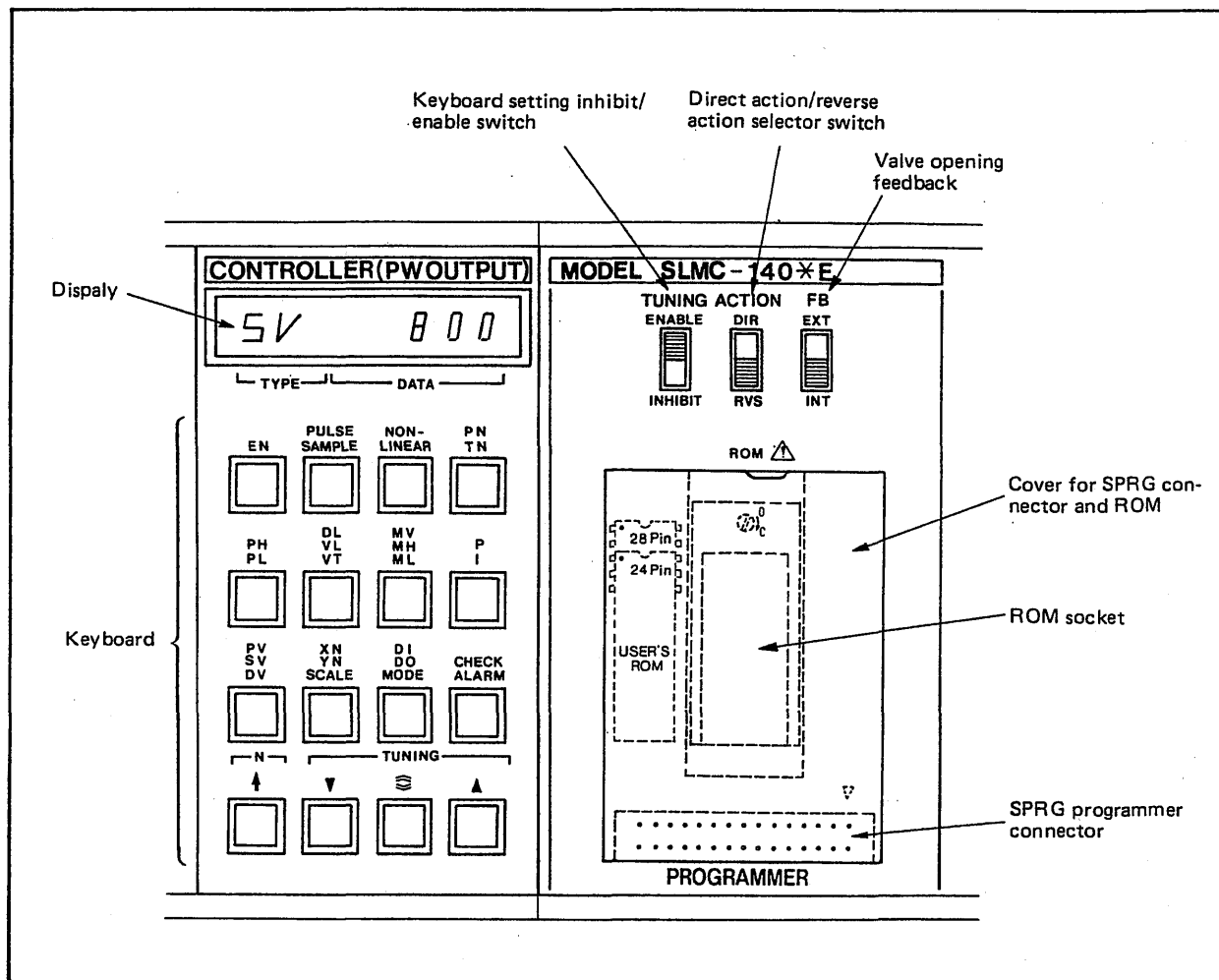
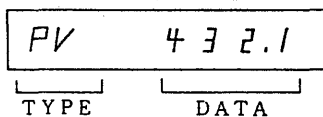

Figure 5-2-5. Setting Slide Switches.

- (1) Display.
Displays the data type code (TYPE) and data value (DATA) for data selected from the keyboard.

(Display example)



- (2) Keyboard.
Used for setting parameters, displaying and changing data, and so on. The names and functions of pushbutton switches are shown in Tables 5-1-1 and 5-1-2.

Table 5-1-1. Names and Functions of Tuning Panel Keyboard Switches.

Keys	Type (TYPE)	Number (N)	Name, Content	Display/Setting Range	Units	Settable	Default Value
EN	EN	1 to 15	E register	-800.0 to 800.0	%	x	-
	CI	1 to 15	CI register	0/1	-	x	-
	DN	1 to 15	D register	-800.0 to 800.0	%	x	-
	CO	1 to 15	CO register	0/1	-	x	-
PULSE	TF	-	Pulse width output setting	0 to 999.9	Seconds	o	40.0
	DZ	-	Valve travel time (full stroke)	0 to 100.0	%	o	5.0
	MW	-	Output dead band	0 to 100.0	%	o	1.0
	BL	-	Minimum time span of output	0 to 100.0	%	o	0.0
	OU	-	Backlash compensation	0 to 100.0	%	o	0.0
	OD	-	Output bias (Number 1 output)	0 to 100.0	%	o	0.0
SAMPLE	ST	-	Output bias (Number 2 output)	0 to -100.0	%	o	0.0
	SW	-	Sample-and-hold PI control parameters	0 to 9999	Seconds	o	0
			Sampling time (period)	0 to 9999	Seconds	o	0
			Control time	0 to 9999	Seconds	o	0
NON-LINEAR	GW	-	Non-linear control and 10-segment line-segment function parameters	0.0 to 100.0	%	o	0.0
	GG	-	Non-linear control; dead band width	0.000 to 1.000	-	o	1.000
	F	01 to 11	Non-linear control; gain	0.0 to 100.0	%	o	0.0 to 100.0 linear set
	G	01 to 11	10-segment linearizer; output setpoint	0.0 to 100.0	%	o	
	H	01 to 11	10-segment linearizer; output setpoint	0.0 to 100.0	%	o	
	I	01 to 11	Line segment functions (Input segment) (Output setpoint)	-25.0 to 125.0	%	o	
	L	01 to 11					
M	01 to 11	arbitrary setpoint (Input segment) (Output setpoint)					
PN	PN	01 to 08	Computational parameters	Engineering units	-	o	0.0
		09 to 16		-800.0 to 800.0	%	o	0.0
		20 to 29		0 to 9999	Seconds	o	0
		30 to 39		-25.0 to 125.0	%	o	0.0
TN	TN	01 to 16	Temporary storage register	-800.0 to 800.0	-	x	-
		PX		-	-	-	-
		PY		-	-	-	-
		PZ		-	-	-	-
			Valve travel time (TF) coefficient	0.000 to 8.000	-	-	-
PH	PH	-	Process variable high-limit alarm setpoint	Engineering units using SCALE	-	o	106.3
PL	PL	-	Process variable low-limit alarm setpoint	Engineering units using SCALE	-	o	-6.3
DL	DL	-	Deviation alarm setpoint	Engineering units using SCALE	-	o	100.0
VL	VL	-	Velocity alarm; PV change in time VT	Engineering units using SCALE	-	o	100.0
VT	VT	-	Velocity alarm; Time setting	1 to 9999	Seconds	o	1
MV	MV	-	Manipulated output signal	-6.3 to 106.3	%	o	-
MH	MH	-	Manipulated output signal; High limit value	-6.3 to 106.3	%	o	106.3
ML	ML	-	Manipulated output signal; Low limit value	-6.3 to 106.3	%	o	-6.3
P	PB	-	Proportional band	6.3 to 9999	%	o	999.9
I	TI	-	Integral time	1 to 9999	Seconds	o	1000
PV	PV	-	Control; Process variable input value	Engineering units using SCALE	-	x	-
SV	SV	-	Control; Setpoint		-	o	-
DV	DV	-	Control; Deviation value		-	x	-
SCALE	XN	1 to 5	Analog input signal register	Engineering units	-	x	-
				Engineering units	-	x	-
	YN	1 to 6	Analog current output signal register Y1	Engineering units	-	x	-
				Engineering units	-	x	-
HI	-	Analog voltage output signal register Y2, 3	Engineering units	-	x	-	
			Engineering units	-	x	-	
LO	-	Auxiliary output data Y4, 5, 6	Engineering units	-	x	-	
			Engineering units	-	x	-	
DP	-	Control function - PV/SV engineering unit display (100% value)	-9999 to 9999	-	o	1000	
			-9999 to 9999	-	o	0	
DI	DI	1 to 4	Status inputs	1 to 4	-	o	3
				1 to 4	-	o	3
DO	DO	1 to 16	Status output and internal status *1	1 to 4	-	o	3
				1 to 4	-	o	3
MODE	MODE	1 to 5	Operation mode	Refer to Table 5-1-2.	-	o	0
CHECK ALARM	CHECK ALARM		Self-diagnostic; Cause of fault is indicated by code. Process alarm; Cause of alarm is indicated by code.	Refer to section 5-4.			
N ↑			Item number update (updates the type number N)	-	-	-	-
▼			Data decrease setting	-	-	-	-
⊞			Setting speed (Press together with ▼ or ▲ buttons.)	-	-	-	-
▲			Data increase setting	-	-	-	-

--: Not Applicable o: Yes x: No *1: DO1 and DO2 are pulse width outputs.

Table 5-1-2. Operation Modes (MODE).

MODE	Set point	Set Conditions	Default Value
1 (Recovery from power failure)	0	COLD start. The controller is restarted in manual mode, with manipulated output set to OFF.	0
	1	HOT start. The controller is restarted with exactly the same mode and status it had immediately before the power failure.	
2 (<input type="checkbox"/> mode)	0	<input type="checkbox"/> mode canceled; the setpoint is set with the front-panel SET pushbutton switches, without remote setting.	0
	1	In <input type="checkbox"/> mode, the data stored in A1 register is set as a setpoint.	
	2	In <input type="checkbox"/> mode, the data transmitted from supervisory system is set as a setpoint.	
3 (Control element 2 setting)	0, 1	This mode cannot be used.	0
4 (Supervisory system backup)	0	When the supervisory system (*1) fails, operation mode is switched to manual (M) to enable controller output to be manipulated manually.	Set when performing communications with a supervisory system.
	1	When the supervisory system (*1) fails, the setpoint is held in auto (A) mode for automatic control.	
5 (Supervisory setting)	0	Setting/operation by a supervisory equipment (*2) is enabled.	
	1	Setting/operation by a supervisory equipment (*2) is enabled.	

*1 Supervisory system: System, such as computer, CENTUM or μ XL.
 *2 Supervisory equipment: Computer, CENTUM or μ XL Operator Station.

(3) TUNING switch.

The function of the TUNING pushbutton switches (, ,) on the keyboard is enabled/inhibited.

ENABLE: Settings and alterations are allowed.
 INHIBIT: Settings and alterations are not allowed.

(4) Action switch

Set direct (DIR)/reverse (RVS) control operation. In automatic mode with 0 deviation the output indicator displays MV. MV is feedback value when FB switch is set to EXT side or 50% value when set to INT side. Refer to the following section (5).

$$\text{Deviation (E)} = \text{process variable (PV)} - \text{minus setting value (SV)} \dots (1)$$

When deviation (E) as defined in (1) is increased, the manipulated output indication increases from the MV value, and valve operating output 1 goes ON in direct action (DIR).

In reverse action (RVS), an increase of deviation (E) produces a decrease of the manipulated output indication and valve operating output 2 goes ON.

Investigate the relationship between the controlling process and the OPEN/CLOSE action of the actuator and set the ACTION switch and the control valve action label.

(5) FB switch

Designates the necessity/unnecessity of valve opening feedback signal FB.

When a valve opening feedback signal is used, set the FB switch to EXT side. If no feedback signal is used, set the switch to INT side.

The manipulated output indication changes depending on the FB switch setting. Normally, the program is written using the following steps.

Valve opening feedback used	Not used	Explanation
LD XN	Reads feedback signal
ST A09	Connects to feedback terminal
LD X1	LD X1	Reads process variable
BSC	BSC	Pulse width output computation
ST Y1	ST Y1	Display MV on the output indicator
END	END	Program completion

When the FB signal is used, the valve opening feedback value is given to the BSC function module by LD XN and ST A09 instructions. The output indicator indicates the valve opening feedback value by ST Y1 instructions after BSC execution. During manual operation mode (M), it indicates the value that is added/subtracted the manual operating quantity to/from the FB (feedback) indicating position. During cascade (C) mode or automatic (A) mode, only the feedback valve is indicated.

When no feedback signal is used during C, A, or M mode, the output indicator displays 50% position in case of no manipulated output. And if the manipulated output occurs, the indicator indicates the value that is added/subtracted the

output quantity to/from 50% position during output. After the manipulated output is completed, the 50% position is indicated again.

The pulse width output is connected to valve operating output 1 and valve operating output 2 through the BSC control computation. The relationship between the manipulated output and the indication during manual operation mode is shown in Figure 5-1-6 and 5-1-7.

(6) ROM socket

The ROM containing the user's program is installed in this socket. The ROM is fixed when the ROM socket lock is turned clockwise. The ROM can be removed by turning the lock counterclockwise.

(7) CONNECTOR (PROGRAMMER).

This is used for the connecting cable of SPRG programmer.

● Output indication when valve opening feedback is used

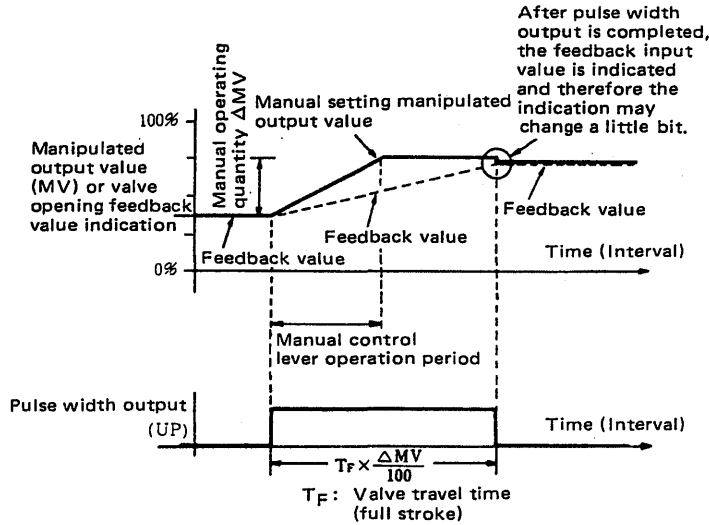

Figure 5-1-6. Output and Indication during Manual Operation Mode (Valve Opening Feedback Used).

● Output indication when valve opening feedback is not used

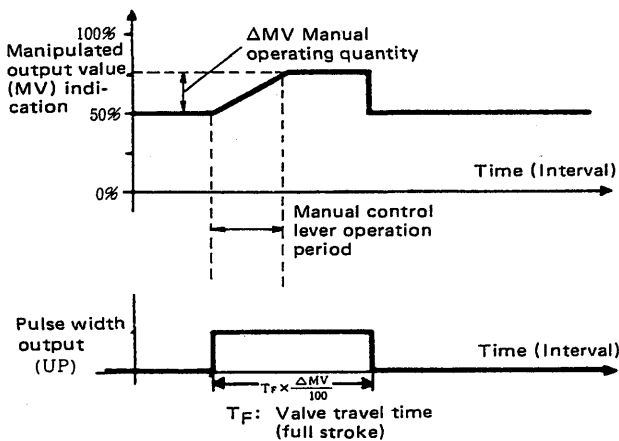

Figure 5-1-7. Output and Indication during Manual Operation Mode (Valve Opening Feedback Unused).

■ Keyboard operation (See Figure 5-1-8.)

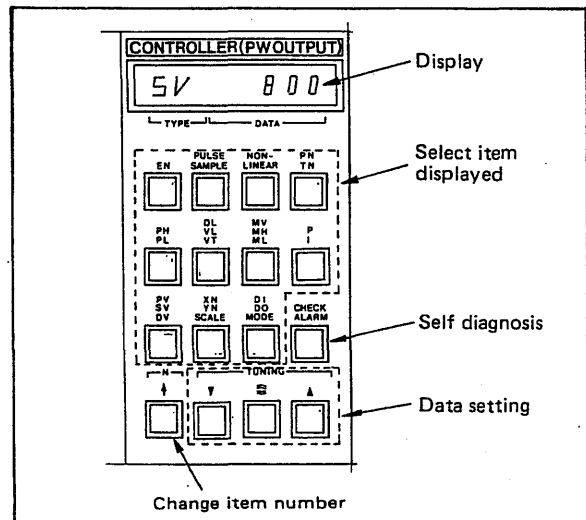

Figure 5-1-8. Functions of Keyboard.

(1) Displaying item (TYPE).

Press the key of desired item to display the data type code of the item and its value.

If more than one item is assigned to a key, the displayed item is changed each time the key is pressed.

(Example of key operation and display)

- 1 PV·SV·DV key. The arrow mark indicates one operation of the key.

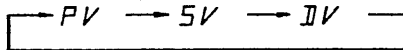

- 2 NONLINEAR key. The arrow mark indicates one operation of the key.

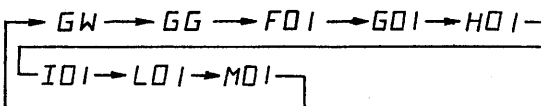

(2) Changing the item number.

The item number can be changed by pressing the N key.

(Example of key operation and display)

- 1 XN key. The arrow mark indicates the effect of pressing the key once.

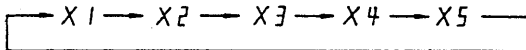

(3) Changing data value.

A data value can be increased or decrease by pressing one of the TUNING keys (). These keys are active only when the TUNING slide switch is set to the ENABLE side.

: Data increase setting.

: Sets fast rate of change. (Press simultaneously with or).

: Data decrease setting.

(4) Self diagnosis.

The operating state of the controller can be checked by pressing the CHECK or ALARM key. The method of display is identical with (1).

(5) Display turn-off.

When data setting is completed and all the key operations are finished, the display goes out automatically after approx. 30 minutes. This eliminates unnecessary current consumption. The display lights again when key operation is restarted.

Unused signals and parameters

Input-output signals, and parameters that are not used in the application program, can also be "displayed" and "set" by keyboard operations. However, such data remain irrelevant to the execution of control and computation, and have no effect.

5-2. Preparations for Operation.

Perform preparation with the controller installed in the panel, or removed and placed on a work table. (Suppose that the instrument module is in the housing.)

Removing the instrument module from the housing:

- (1) To remove the instrument module, push up the stopper located below the front panel. When it is drawn out halfway, the instrument module is stopped by an intermediate stopper. (Figure 5-2-1).

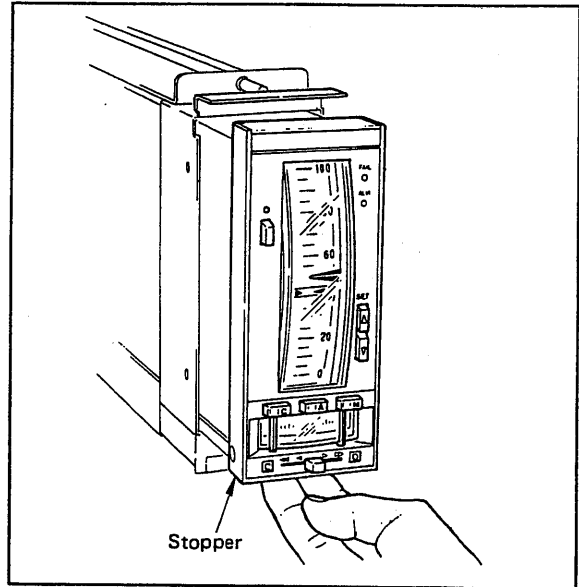

Figure 5-2-1. Removing Instrument Module.

- (2) To remove the instrument module from the housing, push down on the intermediate stopper while pulling the instrument module out of the housing as shown in Figure 5-2-2.

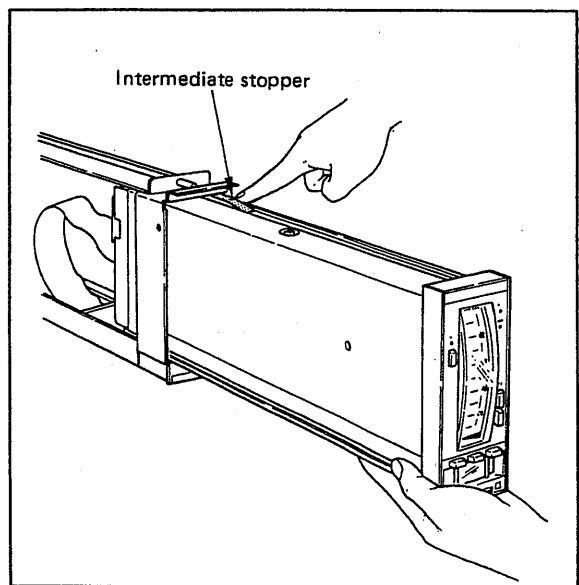

Figure 5-2-2. Removing Instrument Module.

- (3) Facing downward the instrument front panel as shown in Figure 5-2-3, detach the connector from the instrument module by pulling it in the direction shown. Separate the module from the housing.

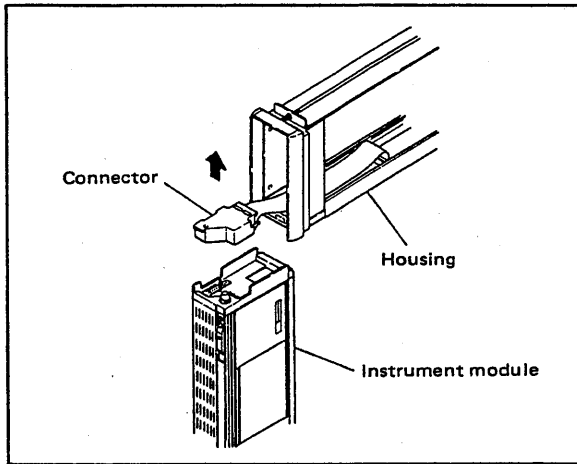

Figure 5-2-3. Removing the Connector.

5-2-1. Check Special Parts are Installed.

Check to see that the fuse, data memory backup battery and user (applications) ROM are installed.

If any of them has not been installed, refer to Section 6-3 "Parts Replacement" for installation procedure.

5-2-2. Preparations for Operation.

- (1) Mounting control valve action labels (Figure 5-2-4). Match the label location with the action (direct or reverse action) of the control valve. The labels can be removed using tweezers or fingers.

- C : Closed (control valve closed direction).
- O : Open (control valve open direction).

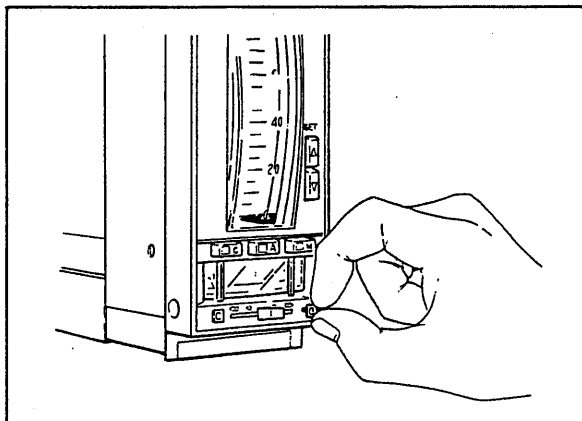

Figure 5-2-4. Mounting Control Valve Action Label.

- (2) Setting of tuning board switches (Figure 5-2-5). Set the DIR/RVS and EXT/INT selector switches on the tuning panel to the required position. Next, turn on the power, and set the TUNING switch to ENABLE. The parameters can now be set from the keyboard.

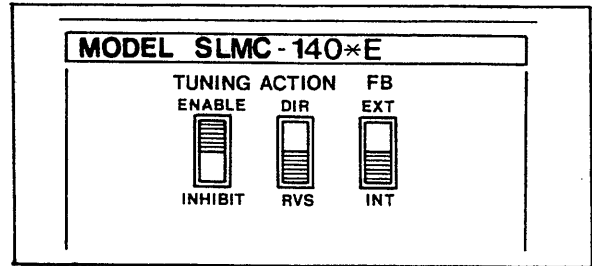

Figure 5-2-5. Setting Tuning Board Switches.

- (3) Pulse width output setting
Each time the PULSE key on the tuning panel is pressed, the following items are displayed.

Display	Content	Setting range
TF	Valve travel time (full stroke)	0 to 999.9 sec.
DZ	Output dead zone	0 to 100.0%
MW	Minimum time span of output	0 to 100.0%
BL	Backlash compensation	0 to 100.0%
OU	Output bias (Number 1 output side)	0 to 100.0%
OD	Output bias (Number 2 output side)	0 to -100.0%

When the SLMC power is turned on for the first time, the above items are all initialized to zero. If TF is 0.0, the alarm (ALM) lamp lights (overranged). So a manipulated output signal is not output even if TEST RUN or RUN instruction are executed.

Valve travel time TF should be specified when creating the program and then should be written in the ROM. Also, set the minimum time span of output MW at the same time.

- a. Valve travel time setting
Set the time (full stroke) necessary for the actuator to go from fully open to fully closed or vice-versa.
- b. Output dead zone DZ, minimum time span of output MW

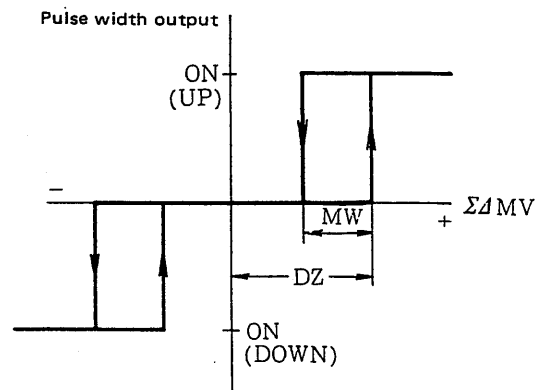

Figure 5-2-6. Pulse Width Output Operation.

The integrated value $\Sigma\Delta MV$ of the computational result (output) for the deviation with 0.2 second period is kept stored until it accords with DZ shown in Figure 5-2-6. As soon as $\Sigma\Delta MV$ exceeds DZ, the pulse width output is output. The MW is the minimum time span of output.

Set MW to a value more than the response time of the actuator. Set MW to 1 or 2% of full stroke if no response time is found.

DZ is used for decreasing the actuator's OPEN/CLOSE frequency. It is recommended that DZ is set to about five times the value of MW.

When $DZ \leq MW$, the output computation with DZ equal to MW may be executed.

c. Backlash compensation: BL setting

Set the backlash compensation BL by ratio % value in the valve travel time to compensate for backlash occurred when the actuator is changed from open to closed position or vice versa.

d. Output bias compensation: OU and OD settings

If a sliding nozzle is used to compensate for the influence of stress, the Controller permits output pulse width compensation by setting the output bias compensators OU and OD. If not necessary, set OU and OD to 0.0%.

e. SLMC/LOCAL transfer

When the actuator is required to be opened and closed by separating it from the SLMC in the field (LOCAL), apply the SLMC/LOCAL status signal to the SLMC to shut down output and to make the operation mode display lamp go on and off. The register FL9 built-in the SLMC is used for communication with the actuator, that is to say the register FL9 reads the contact signal DI_N from the actuator and executes SLMC/LOCAL transfer (see section 5-2-3).

- When $FL9 = 0$, the actuator's valve opens or closes by the manipulated output signal from the SLMC.
- When $FL9 = 1$, the actuator's valve can be opened and close in the field.

The SLMC manipulated output shuts down (D01 and D02 are open) and operation mode lamp just prior to transferring goes on and off. If the operator station is used to communicate with SLMC, OOP (output open) is displayed on the CRT.

(4) Setting of MODE.

Display MODE by keyboard operations, and set the desired mode by pressing pushbuttons \blacktriangle or \blacktriangledown .

(Display and Setting Example)

Pushbutton operation	Display	Remarks
MODE	MODE 1 0	
\blacktriangle	MODE 1 1	If initial "0" setting is O.K., go to the next mode setting.
\uparrow	MODE 2 1	
\blacktriangledown	MODE 2 0	If initial "1" setting is O.K., go to the next mode setting.
⋮	⋮	

To change the mode using \blacktriangle and \blacktriangledown keys, keep the keys pressed for approx. one second. (This time is required to prevent accidental setting.)

(5) SCALE Setting

Set the range to display the process variable and setpoint in engineering units. The setting order is maximum value, minimum value and decimal point.

Maximum value

(HI):

Set the value to be displayed when the internal data is 1.0. A signed 4-digit integer is entered.

Minimum value

(LD):

Set the value to be displayed when the internal data is 0.0. A signed 4-digit integer is entered.

Decimal point

(DP):

Specify the decimal point position by a number (see Figure below).

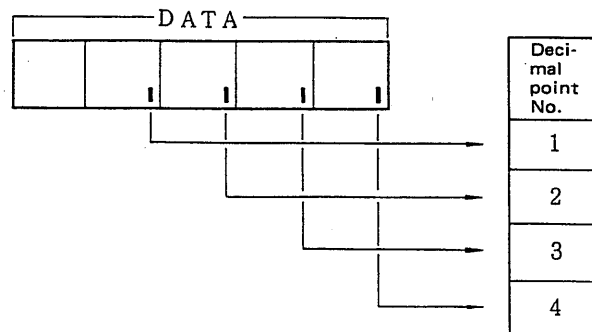

(Example)

When setting the scale to cover the range -10.00 to 40.00

Pushbutton	Display	Description
SCALE	HI 1000 └TYPE┘ └DATA┘	Current HI value is displayed in the DATA part.
▲	HI 4000	☒ may be used simultaneously.
SCALE	LO 00 └TYPE┘ └DATA┘	Current LO value is displayed in the DATA part.
▼	LO -1000	☒ may be used simultaneously.
SCALE	DP 3	Current DP value is displayed in the DATA part.
▼	DP 2	For details of decimal point, see the figure on the previous page. However, use the ▲, ▼ keys to change a setting.

(6) Setting of other parameters.

Set all parameters necessary for control and computation. First write out (on a data sheet) all parameters that must be set, so that you do not forget to set any. Table 5-1-1 above lists the parameters and their setting range.

(Parameter setting example)

When setting integral time to 600 sec.

Pushbutton	Display	Description
I	TI 1000	Current TI value is displayed.
▼	TI 600	☒ may be used at the same time.

Other parameters can also be set in the following sequence.

- 1 Item displayed: Use the eleventh item (type) keys (Figure 5-1-5) to select this.
- 2 Selected item number: Change using **I** key.
- 3 Data (value) setting: Set data values using **▼**, **☒** and **▲** keys.

(7) Initial value, default value

Initial values can be written into ROM — simultaneously with the user program — by the SPRG programmer. If a value set from the keyboard is lost due to power supply failure and lack of data backup battery, this initial value is used as the set value when control is restarted.

Default values are the values when the programmer and the parameter are initialized while connected with the SPRG. When you create a new user program, be sure to initialize the programmer and the parameter. (See Tables 5-1-1 and 5-1-2.)

(8) Inclined mounting

When mounting the instrument at an angle to the vertical, the indicator needs zero adjustment. Refer to Section 6-2 "Inspection, Calibration and Adjustment of Indicator" for instructions on how to perform zero adjustment.

After completing all the necessary preparations, disconnect the power plug, install the instrument in the panel, connect the I/O signal wires, and finally connect the power supply.

5-2-3. Programs Example.

Figure 5-2-7 shows an example of the control loop.

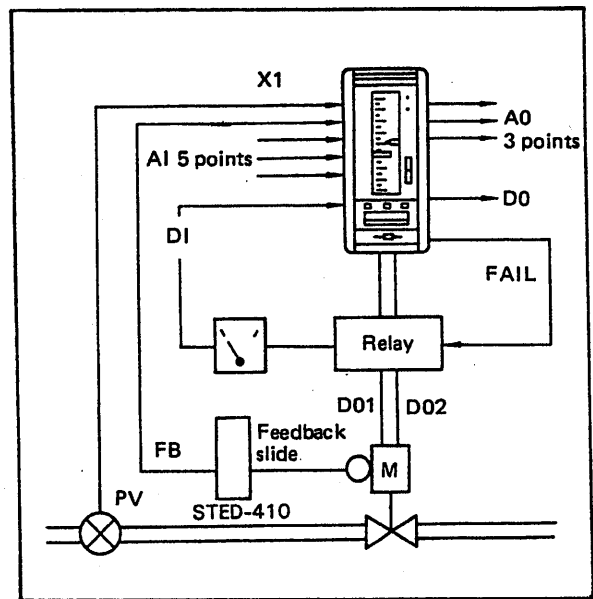

Figure 5-2-7. An Example of Control Loop.

The following shows an example of program listing.

1. LD DI 1 Reads SLMC/LOCAL status
2. ST FL09 Stores to FL 9.
3. LD X2 Valve opening feedback (FB) signal.
4. ST A09 Connects to valve opening feedback (FB) terminals.
5. LD X1 Reads process variable signal
6. BSC Pulse width output computations. (Pulse width output has been performed.)
7. ST Y1 Indicates MV* on the output indicator (see Note below)
8. END

* Slide the FB (see 5-1-3) switch to the EXT side. The output indicator indicates the feedback value in the C, A mode operation and the manipulated value in the M mode operation.

5-3. Startup and Operation.

NOTE

This section explains the procedure for starting up and operating the instrument.

The procedure for starting up and operating the instrument may vary with the computation and control programs used. The example below illustrates simple PI control. The reader should perform the procedure shown in this tutorial example.

5-3-1. Manual Startup.

- (1) Manual operation by manual control lever.
- (a) Of the **C** **A** **M** operation mode transfer switches, select **M**. (The lamp inside the pushbutton lights.) (Figure 5-3-1).

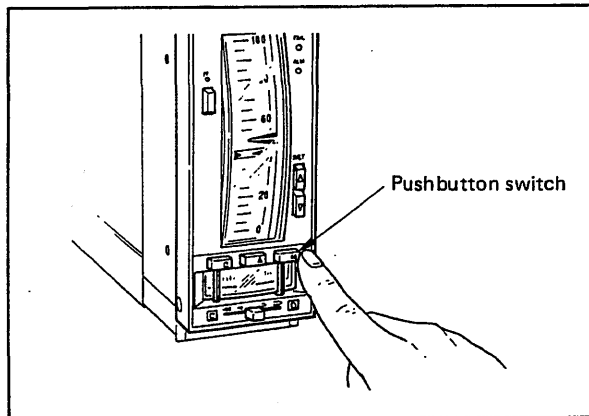

Figure 5-3-1. Selecting the Operation Mode.

- (b) Move the manual control lever left (or right) to adjust the output signal. (Figure 5-3-2).

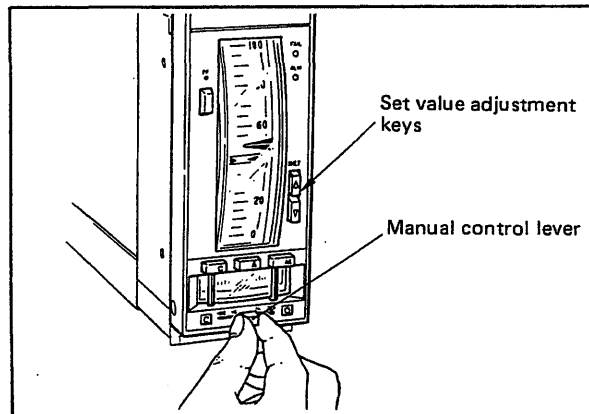

Figure 5-3-2. Manual Control of Output.

- (c) Set the desired value using the SET key switches.

5-3-2 Alarm Check and Transfer to Automatic Operation.

Assume that smooth response has been obtained through manual operation, and that the process variable has stabilized around the set point. Then proceed as follows:

- (1) Alarm check (Figure 5-3-3).
If the ALM lamp on the front panel is on, it indicates that there is some signal failure. Use the **CHECK ALARM** item on the tuning panel, diagnose the failure, and correct the cause of it.
If the FAIL lamp is on, there is some trouble in the controller itself. Refer to Sec. 5-5.
- (2) Transfer from manual to automatic control.
Depress the **C** **A** **M** control mode selector switch marked **A**. The lamp in switch **A** lights, and the controller transfers to automatic mode. No balancing operation is needed when transferring between modes.

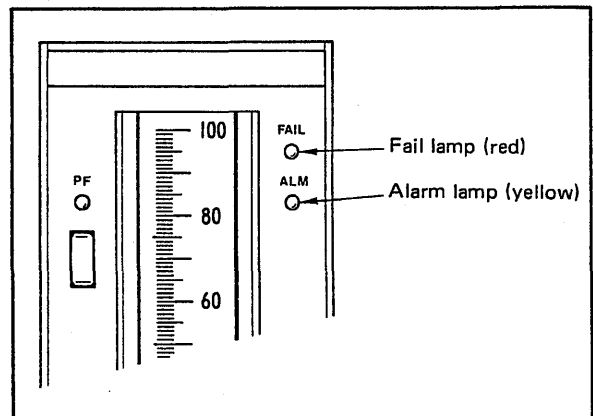

Figure 5-3-4. FAIL Lamp and ALM Lamp.

5-3-3. Normal Operation.

- (1) Transfer between control modes.
The control mode of the controller can be changed freely by depressing the **C** **A** **M** pushbutton switches. (Figure 5-3-1). (Note, however, that direct transfer from **M** to **C** modes is not allowed.) Transfer between modes is bumpless, and no balancing operation is needed.
- (2) Parameter setting on tuning panel.
If parameters must be set or altered, remove the controller module from its housing, and set or alter the parameters on the tuning panel. After setting, set the TUNING switch back to the INHIBIT side, preventing accidental changes to the parameters.

5-4. Automatic Mode Operation.

When applying the controller to an unknown process, it is useful to examine the performance of the process in manual mode.

This can be useful in estimating the proportional band, integral time and derivative time required for automatic mode.

For example, if a small change in the controller output causes a large fluctuation in the process variable value, the width of the proportional band must be increased (the gain must be reduced) to assure stability. In the converse case, the proportional band must be narrowed.

For a process which responds quickly to a change in the controller output, the integral and derivative time constants must be short. Conversely, for a process having a long recovery time, the integral and derivative time constants must be long.

- Standard P and I constants setting for motor-operated valve control.

If a process is considered to have only the following elements its gain (K), dead time (L) + first-order lag (T), the standard proportional band (PB) and integral time (TI) constants are given by next expression:

$$PB = K \cdot n (1 + L/T) \times 100 (\%)$$

where: $n = 0.8$, T: first-order lag

L: dead time, K: process gain

If a flow noise occurs, it is to be desired that n is more than 0.9 to decrease the ON/OFF frequency of the actuator.

$$TI = T \text{ (sec.) when } L/T \leq 0.5$$

$$TI = T + L/4 \text{ (sec.) when } L/T > 0.5$$

5-5. Action to be Taken When FAIL or ALM Lamps Light.

Any faults in the controller or in the signal connections are indicated by the FAIL or ALM lamps lighting. If either of these lamps lights (or begins flashing), please take appropriate measures (as described below) without delay.

5-5-1. Action to be Taken When the FAIL Lamp Lights.

When the FAIL lamp lights and the FAIL contact output opens, this means that a serious fault has occurred in the controller.

- (1) If the SLMC fails, the pulse width output remains open (OFF).

(Note) The output can be turned ON and OFF by adjusting the manual control lever.

- (2) Select the "CHECK" key on the tuning panel, research the cause of failure corresponding to the displayed number (see Section 5-5-4).

5-5-2. Action to be Taken When the ALM Lamp Lights.

The ALM lamp lights if the high or low limit alarms of the controller operate, or when input-output signals are disconnected.

Select the "CHECK" and "ALARM" key on the tuning panel, and research the cause of failure corresponding to the displayed number. (Refer to 5-5-4 and 5-5-5.)

Take appropriate measures suited to the cause of the fault.

5-5-3. Action to be Taken When the ALM Lamp Flashes.

The ALM lamp begins flashing if the voltage of the data memory backup battery drops. Replace the battery with a new one. (Refer to 6-3-4 for replacement procedure.)

Notes:

- (1) If the ALM lamp begins to flash during normal operation, replace the battery as soon as possible.
- (2) The flashing of the ALM lamp has precedence over its continuous lighting. Thus, other alarms cannot be displayed while the lamp is flashing. (But other alarms can still be displayed on the tuning panel display.)

5-5-4. CHECK Display.

The CHECK display items are listed below.

Lamp	CHECK display	Diagnosis
-	00	Normal.
FAIL	01	Fault in A/D converter.
FAIL	02	Fault in D/A converter.
ALM	04	Arithmetic range overflow! ^(*1)
ALM	08	Input overrange.
FAIL	10	Unmounted or failed user ROM! ^(*2)
ALM	20	Data memory backup battery not installed, or (Lamp flashing) low battery voltage.
ALM	40	Current output signal line open or short circuit! ^(*3)
ALM	80	RAM memory data lost! ^(*4)
ALM	PWRERR	Supply voltage too low
FAIL	-	Microprocessor faulty (display not possible).

- (*1) Even when the valve travel time TF (see 5-2-2) is set to 0 second, the arithmetic range overflow is displayed.
- (*2) FAIL lamp lights even when programming control function modules SSC and CSC by using an SPRG programmer.
- (*3) In this case, no supervisory computer's OPS (described in Table 5-1-2) displays OOP.
- (*4) When ALM lamp lights and the "CHECK display" is 80, set all parameters on the side panel again, because they are initialized.

If two or more faults occur at the same time, the displayed value is the total of the individual display values (sum of hexadecimal numbers).

(Examples)

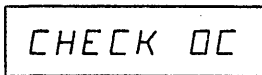

0C = 04 + 08 (arithmetic range overflow, input overrange)

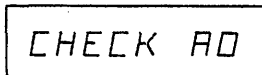

A0 = 20 + 80 (battery low, data lost)

The displayed value returns to 00 upon removal of the causes of the fault. However, the display 80 (internal data lost) does not return to 00 automatically.

The key must be used to set the display to 00.

5-5-5. ALARM Display.

The alarm state of the control function is display as a 2-digit number. Also, the ALM lamp lights.

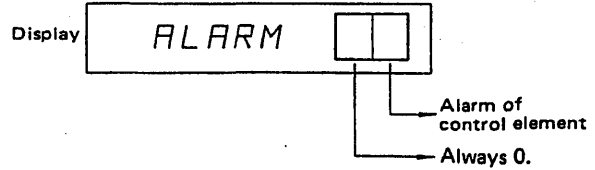

ALARM display	Diagnosis
0	Normal
1	High limit alarm
2	Low limit alarm
4	Deviation alarm
8	Velocity alarm

If two or more alarms occur at the same time, the total of the individual display values is indicated. (Hexadecimal addition).

(Examples)

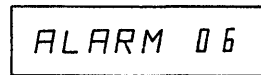

6 = 2 + 4 (Lower limit alarm and deviation alarm)

The display value reverts to 0 when the alarms are cleared.

5-6. Operation Mode Display Lamp Flashing.

The SLMC operation mode display lamp flashes when the SLMC is under the following operating conditions.

5-6-1. Field Operation (When SLMC is Transferred to LOCAL Operation).

When the register FL9 is changed to 1 (LOCAL side) by the contact signal from the field during operation, the operation mode display lamp just prior to be transferred goes on and off to inform the operator in the field (both DO1 and DO2 are open).

When the register FL9 is changed to 0 (SLMC side) by the contact signal from the field again, the display lamp changes from flashing to lighting and begins to control in the lighting operation mode without delay.

5-6-2. Backup Operation.

The backup operation is carried out when the supervisory system (i.e. computer, CENTUM or μ XL) are abnormal. The backup operation mode should be specified to manual (MAN) or automatic (AUT) previously (see 5-1-3). In the backup operation, the C mode display lamp flashes in spite of the backup operation mode specified previously. However, even if the supervisory system goes abnormal in manual or automatic operation modes, the backup operation is not carried out.

When the SLMC under the backup mode is transferred to the LOCAL operation, it provides no backup mode even if the supervisory system is defective.

(Note 1) When the SLMC under the backup mode operation is transferred to the LOCAL operation, the operation in the field has priority.

(Note 2) To check whether the operation mode C display lamp flashing results from the LOCAL operation or the supervisory system failure, call and check for DI_N contact status (the terminal transmitted the contact signal from the field) using the tuning panel: LOCAL operation for closed contact (1) and supervisory system failure for open contact (0).

5-7. Connection with SPRG Programmer.

To change the setting data and control program, use the SPRG programmer. Consult IM 1B4W1-02E for more detailed SPRG instructions.

This section covers connecting procedures with the SPRG.

WARNING

Never connect or remove the SPRG programmer with the SLMC turned on.

5-7-1. SPRG Programmer Connecting.

To connect the SPRG programmer to SLMC, proceed as follows:

- (1) Turn off both the SLMC and SPRG.
- (2) Set the SPRG to the PROGRAM mode.
- (3) Connect the SPRG cable connector to the SLMC (see Figure 5-7-1).
- (4) Turn on the SPRG.
- (5) Turn on the SLMC.

5-7-2. Removing the SPRG.

To remove the SPRG from the SLMC, proceed as follows:

- (1) Set the SPRG to the PROGRAM mode.
- (2) Turn off the SLMC.
- (3) Turn off the SPRG.
- (4) Remove the SPRG cable connector from the SLMC.

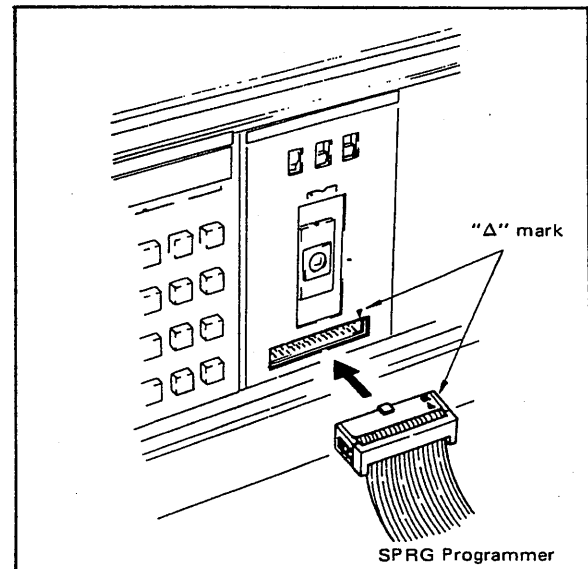

Figure 5-7-1. Connecting with SLMC.

6. MAINTENANCE.

This chapter explains the indicator adjustment and parts replacement procedures.

6-1. Test Equipment Required for Adjustment.

Standard DC voltage source:

- Type 7651, manufactured by YOKOGAWA, or equivalent: 1 unit
- SPRG programmer: 1 unit

6-2. Inspection, Calibration and Adjustment of Indicator.

6-2-1. Creating Adjustment Program.

Connect the controller to be adjusted and the SPRG programmer, and create the following program.

(Adjustment program)

Step	Program
01	LD X2
02	ST A01
03	LD X1
04	BSC
05	LD X3
06	ST Y1
07	END

No other operations — such as setting of parameters and so forth — are needed.

After writing the program, set the SPRG programmer mode to TEST RUN, set MODE2 of the SLMC controller tuning panel to "1", and set the C/A/M switch to the **C** mode. Then perform the following adjustment.

6-2-2. Adjusting Zero Point of Process Variable Indicator (Moving Coil Type).

- (1) Apply a 3.0 V DC standard voltage to input terminal X1 (terminal no. 1(+) and 2(-)) from a standard voltage source.
- (2) Check that the process variable pointer is at the 50% \pm 0.5% calibration mark on the scale.
- (3) If the indication is not within the specified range, adjust the zero adjustment screw as shown in Figure 6-2-1 until the pointer correctly indicates 50%.
- (4) Change the input signal in turn to 1.0V, 2.0V, 4.0V and 5.0V, and ensure that the indication is respectively 0%, 25%, 75% and 100%, using the calibration marks. Tolerance for each indication is \pm 0.5% of the span.

- (5) If the indication is not within the \pm 0.5% tolerance at any position, again input 3.0 V DC, and adjust the indicated value slightly — within the range 50% \pm 0.5%.
- (6) Repeat step (4). As necessary, repeat steps (4) and (5) until all points fall within the tolerance range.

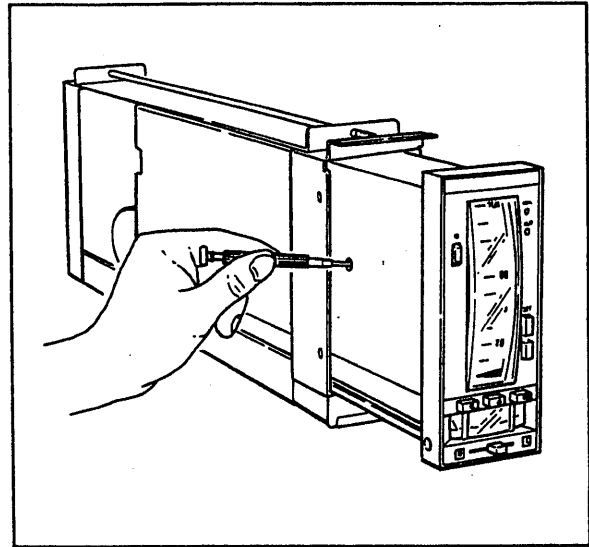

Figure 6-2-1. Adjusting Zero Point of Set Value Indicator.

6-2-3. Adjusting Zero Point of Set Value Indicator (Moving Coil Type).

- (1) Apply the standard 3.0 V DC voltage to input X2 (terminals 3(+) and 4(-)) from a standard voltage source.

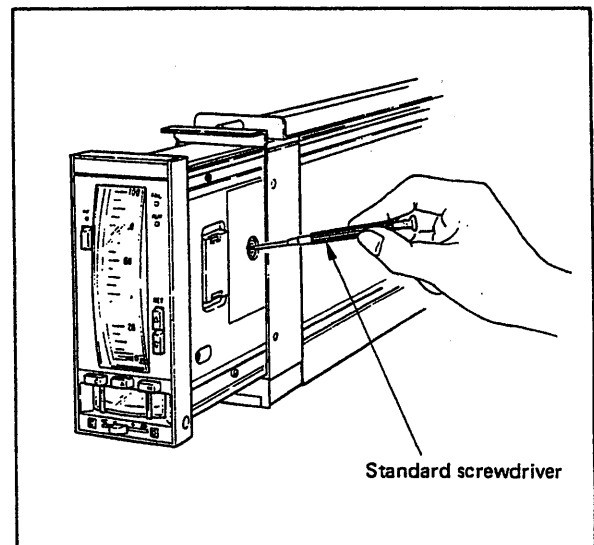

Figure 6-2-2. Adjusting Zero Point of Process Variable Indicator.

- (2) Adjust using the same procedure as described in the process variable indicator (6-2-2). Figure 6-2-2 shows zero point adjustment for set value indicator.

6-2-4. Adjusting Fluorescent Bar Graph Indicator.

It is unnecessary to adjust zero point of either the process variable or set value indicators. Perform checks (1), (2) and (3) of par. 6-2-2.

6-2-5. Adjusting Zero Point of Control Output Indicator.

- (1) Apply the standard 3.0 V DC voltage to input terminal X3 (terminal nos. 5(+) and 6(-)) from a standard voltage source.
(In this case, keep the current output terminals A(+) and B(-) short circuited.)
- (2) Make sure that the output indicating pointer is just on the thick center scale mark. The tolerance is $\pm 2.5\%$ (Equivalent to 1/2 of a scale division.) (See Figure 6-2-3.)

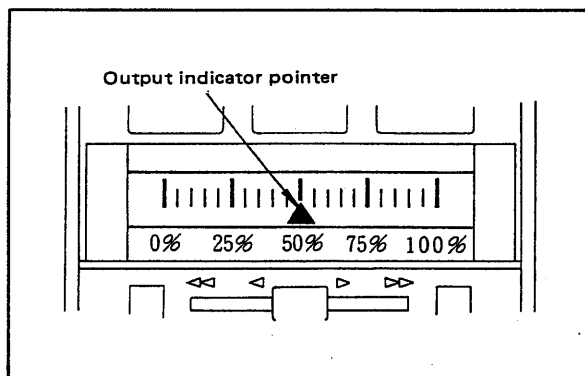

Figure 6-2-3. Output Indicator Center Scale Mark.

- (3) If the pointer is not within this tolerance range, turn the zero adjustment screw as shown in Figure 6-2-4 until the pointer is aligned with the center scale mark.
- (4) Change the input signal to 1.0 V, 2.0 V, 4.0 V and 5.0 V DC in turn, and make sure that the pointer aligns respectively with main scale marks on scale. The tolerance is $\pm 2.5\%$ of the span (1/2 of a scale division).
- (5) If the indication is not within this range at any position, input 3.0 V DC, and adjust the indicated value within the tolerance range.
- (6) Repeat step (4). Repeat steps (4) and (5) as necessary until all points fall within the tolerance range.

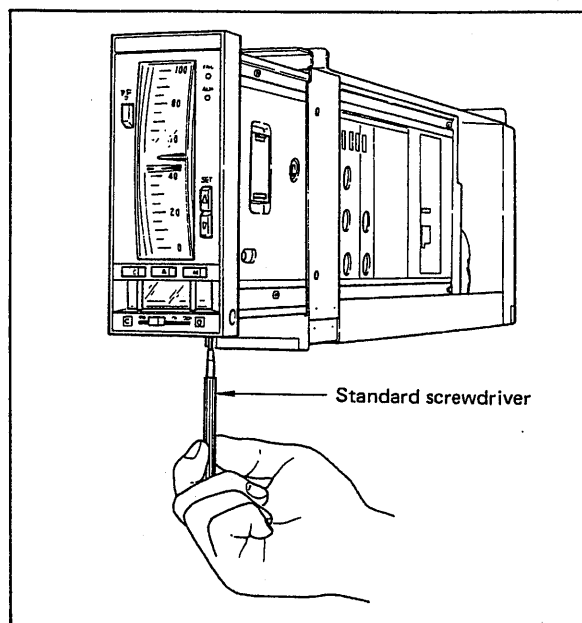

Figure 6-2-4. Adjusting Zero Point of Output Indicator.

6-2-6. Inclined Mounting.

If the instrument is to be mounted at an angle, adjust the process variable indicator (6-2-2) and set value indicator (6-2-3) with the instrument mounted at the actual mounting angle.

6-2-7. Adjusting Brightness of Fluorescent Bar Graph Indicator.

The brightness of the fluorescent bar graph can be adjusted as shown in Figure 6-2-5.

Note: Do not increase the brightness; otherwise, this may shorten the life of the fluorescent tube.

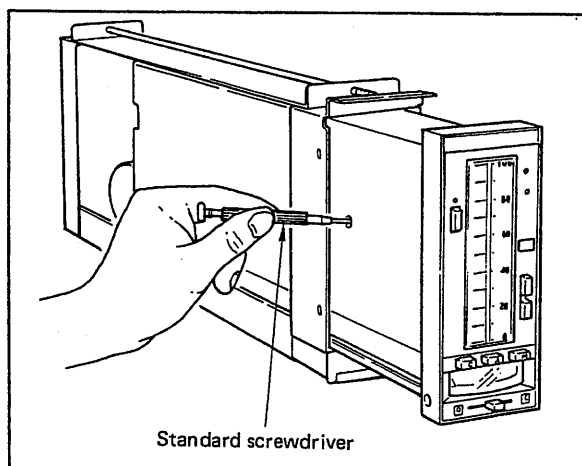

Figure 6-2-5. Adjusting Brightness of Fluorescent Bar Graph Indicator.

6-2-8. Setting Scale of Digital Display.

Note: Setting of the 8-digit DIP switch should be performed with extreme care, using a small screwdriver or finger nail.

The fluorescent bar graph type instrument is provided with a 4-digit display on the right side of the bar graph indicator on the front panel.

The numeric value displayed on the digital display corresponds with that displayed on the bar graph indicator scale.

When the scale plate is changed, the digital display setting must also be changed by the following procedure.

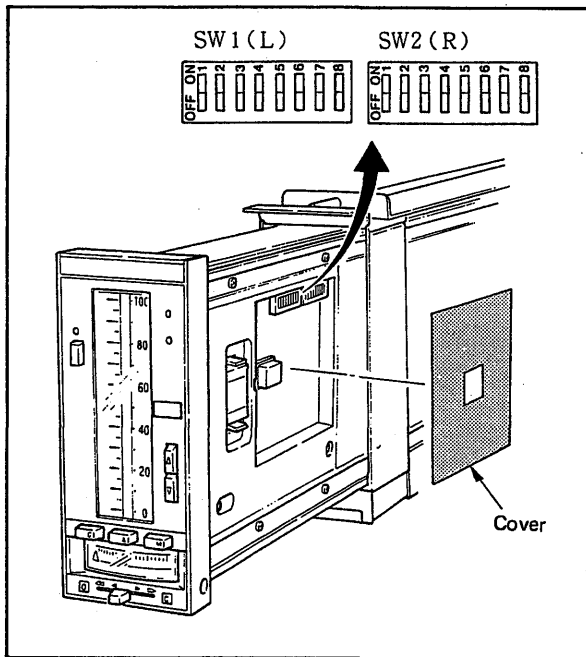

Figure 6-2-6. 8-digit DIP Switch.

- (1) Remove the cover as shown in Figure 6-2-6.
- (2) Two 8-digit DIP switches (L and R) are visible. (See Figure 6-2-6.)
- (3) The DIP switch setting direction mark is printed on the scale plate. (See Figure 6-2-7.)
- (4) Set the DIP switches as indicated by the direction mark of the scale plate; the digital display coincides with the scale marks of the scale plate.
- (5) To display a scale range which is different from the scale range already set, use the four-digit display unit and set the eight-digit DIP switch:

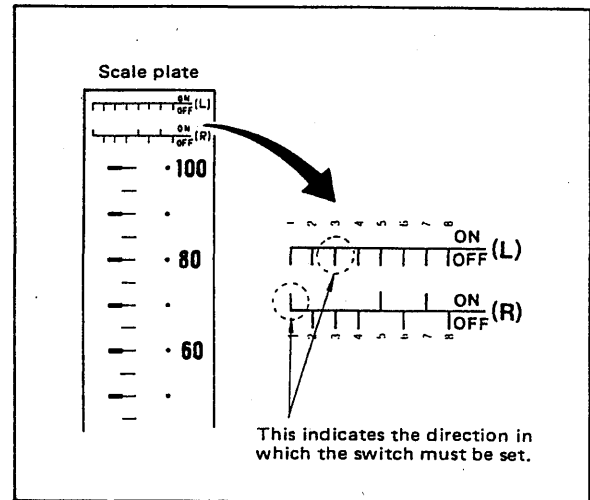

Figure 6-2-7. DIP Switch Setting Direction Mark Printed on the Scale Plate.

- a. Select the desired display values (minimum and maximum values) from Table 6-1.
- b. Set binary values which correspond to these minimum and maximum values on SW1(L) and SW2 (R). Nos. 1 to 7 of SW1 (L) are used for setting the minimum value, and Nos. 2 to 8 of SW2 (R) are used to set the maximum value.

Notes:

1. Values outside those given in Table 6-1 cannot be displayed.
2. The display range of the four-digit display unit is -1999 to 4999.
3. The reading in the four-digit display unit is linear in relation to the input (1 to 5 V DC).

(6) Decimal Point Position (D.P.) Setting.

When the four-digit display values include decimal points, separate decimal point setting is required in addition to the maximum and minimum value setting described above.

Set No. 8 of SW1 (L) and No. 1 of SW2 (R) as follows according to the decimal point position required. (See Figure 6-2-8).

Table 6-1. Display Values Given by Digital Display Unit and Corresponding DIP Switch Settings.

Display Value (Minimum or Maximum Value)	DIP Switch Setting	Display Value (Minimum or Maximum Value)	DIP Switch Setting
-1999	1101100	1600	0010000
-1900	1101101	1700	0010001
-1800	1101110	1800	0010010
-1700	1101111	1900	0010011
-1600	1100000	2000	0010100
-1500	1110001	2100	0010101
-1400	1110010	2200	0010110
-1300	1110011	2300	0010111
-1200	1110100	2400	0011000
-1100	1110101	2500	0011001
-1000	1110110	2600	0011010
-0900	1110111	2700	0011011
-0800	1111000	2800	0011100
-0700	1111001	2900	0011101
-0600	1111010	3000	0011110
-0500	1111011	3100	0011111
-0400	1111100	3200	0100000
-0300	1111101	3300	0100001
-0200	1111110	3400	0100010
-0100	1111111	3500	0100011
0000	0000000	3600	0100100
0100	0000001	3700	0100101
0200	0000010	3800	0100110
0300	0000011	3900	0100111
0400	0000100	4000	0101000
0500	0000101	4100	0101001
0600	0000110	4200	0101010
0700	0000111	4300	0101011
0800	0001000	4400	0101100
0900	0001001	4500	0101101
1000	0001010	4600	0101110
1100	0001011	4700	0101111
1200	0001100	4800	0110000
1300	0001101	4900	0110001
1400	0001110	4999	0110010
1500	0001111		

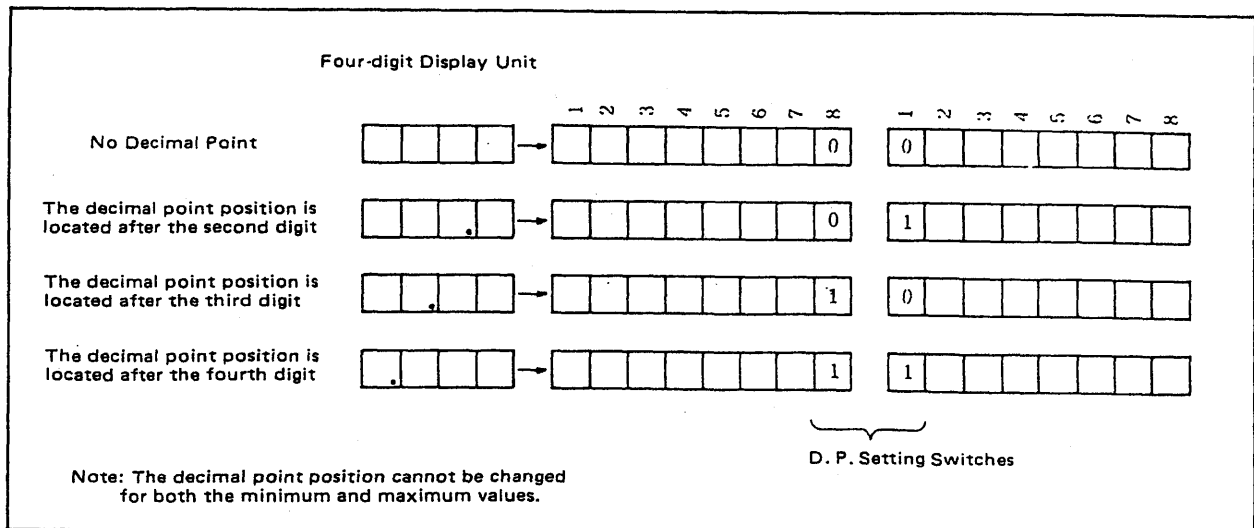

Figure 6-2-8. Decimal Point Position Setting.

6-3. Parts Replacement.

6-3-1. Replacing Nameplate.

Draw out the instrument module a little, and open the lid located on the top of the front panel. Remove the nameplate, and install a new one. (Figure 6-3-1).

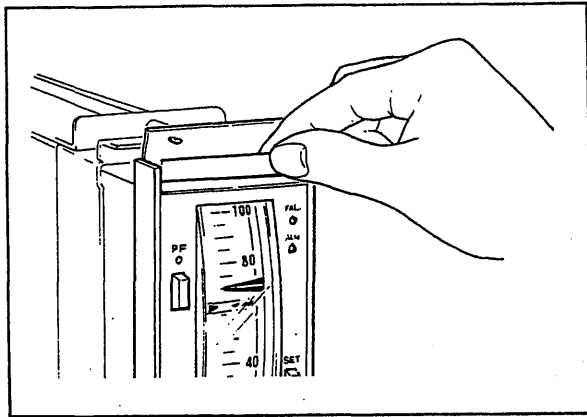

Figure 6-3-1. Replacing Nameplate.

6-3-2. Replacing Scale.

Open the lid on the top of the front panel. Remove the scale plate retaining cap* using a small standard screwdriver. To remove the scale, use a pair of tweezers as shown. Insert a new scale plate, and replace the cap*. (*Moving coil type only).

(Removing the scale plate)

- Contact the engraved face and rear of the scale plate as little as possible when removing the scale plate.
- To clean a scale plate, lightly rub the plate with a soft cloth or suitable equivalent (do not use alcohol or other solvents as they can separate the markings from the scale plate).

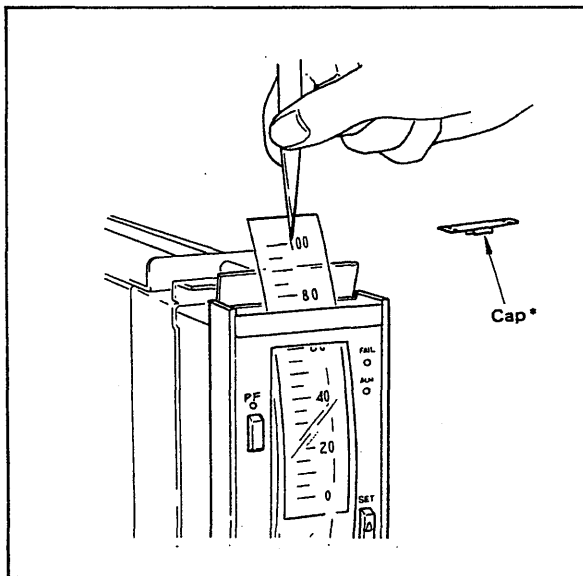

Figure 6-3-2. Replacing Scale Plate.

6-3-3. Replacing Fuse.

If it seems that the fuse may be faulty, check the inside of the fuse holder for contamination or poor contact with fuse.

Recommended replacement interval: About 3 years.

- (1) To remove the fuse, unscrew the fuseholder cap (turning it in the direction marked on the cap (counterclockwise); the cap and fuse may then be removed.
- (2) Install a new fuse of the correct rating. Replace the cap securely.

Note: Use the dedicated fuse (S9510VK). Do not use a fuse for other products.

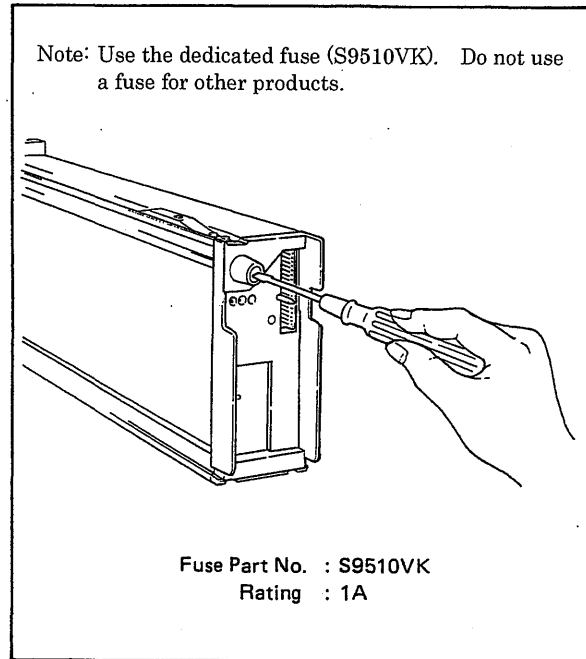

Fuse Part No. : S9510VK
Rating : 1A

Figure 6-3-3. Replacing the Fuse.

6-3-4. Replacing Data Memory Backup Battery.

If the ALM lamp on the front panel of the instrument begins flashing, please replace the battery without delay.

Recommended replacement intervals:

- about 5 years (changing, at ambient temperature below 45°C).
- about a year (shelf-life, at ambient temperature below 45°C)

NOTE

Leave power applied to the instrument while replacing the battery. If the battery is removed while the power is off, some data (parameter) settings may be lost.

- (1) Draw out the controller module a little from the housing, and remove the battery cover and the battery. (Figure 6-3-4 and 6-3-5.)
- (2) Install a new battery, and fit the battery cover securely.
- (3) Make sure that the ALM lamp has stopped flashing.

(Precautions for storage and handling of data memory backup batteries)

- (1) Storage conditions:
 - Ambient temperature: -10 to 60°C .
 - Ambient humidity: 5 to 95% (non-condensing).
 - Location free from corrosive gases.
- (2) Where possible, replace all the batteries at once. Be sure to observe correct battery polarity when installing batteries.
- (3) When measuring the battery voltage, be sure to use a high impedance voltmeter. Do not attempt to measure the voltage with a circuit tester or the like. Voltage: at least 2.45 V DC.

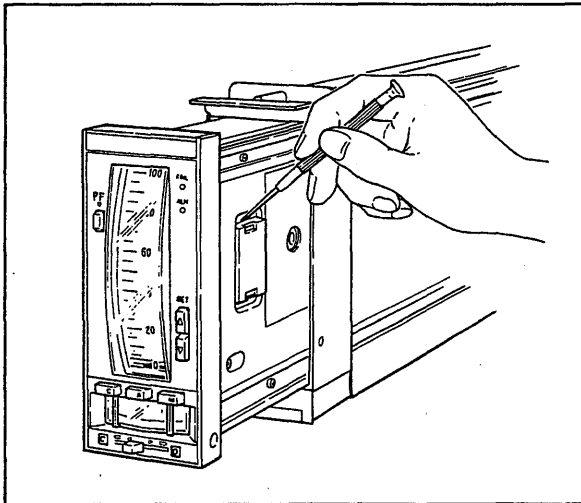

Figure 6-3-4. Removing Battery Cover.

- (4) Cautions in handling batteries
 - Do not charge batteries.
 - Do not heat or put into a fire.
 - Do not short the positive and negative poles together.
 - Do not apply shock; do not attempt to disassemble.

6-3-5. Replacing User ROM.**CAUTION**

Do not attempt to install or remove the user ROM while the instrument is energized; otherwise, the controller mode may switch to FAIL, and the ROM may be damaged.

(Precautions in handling user ROM)

The user ROM is a EPROM — a MOS (metal oxide semiconductor) IC. This type of IC must be handled carefully, as it may be damaged by static electricity. Note also that the program written into it will be lost if ultraviolet rays are applied through the window of this element.

Observe the following cautions when handling the ROM:

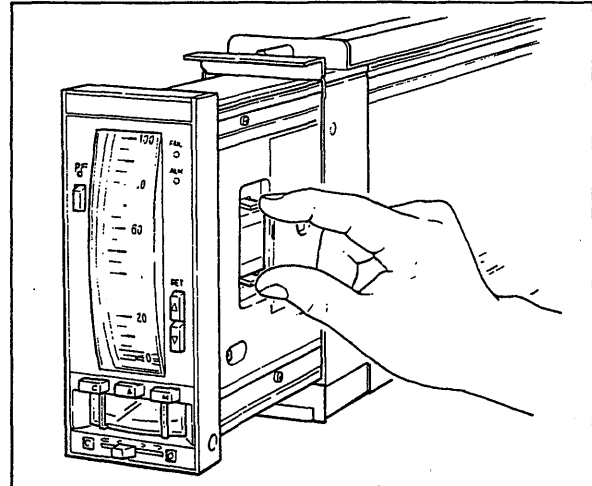

Figure 6-3-5. Removing Battery.

- **Cautions against static electricity:**
Be sure to use a conductive mat when carrying and storing this element. Do not bring the EPROM into contact with clothes and other substances that can be charged easily. Do not handle the EPROM using chemical fiber gloves.
- **Cautions against ultraviolet rays:**
Do not remove the seal of EPROM except when erasing the contents.
When attaching a new EPROM to the controller, be sure to affix the specified seal to the EPROM.
- **Caution not to deform pins:**
If the pins are deformed, straighten them, taking care not to apply force to the root of each pin.

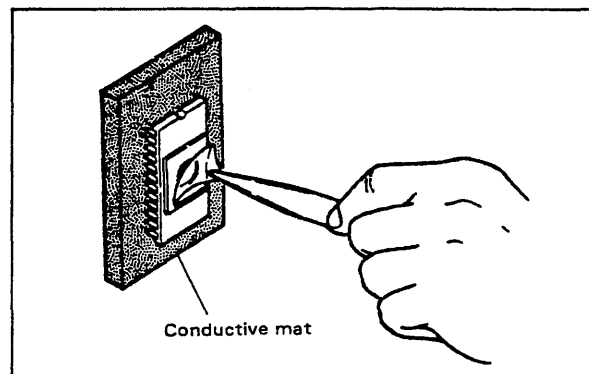

Figure 6-3-6. ROM Seal.

To replace the user ROM, proceed as follows:

- (1) Removing user ROM.
 - a) Turn off the power supply to the instrument. (Leave the backup battery in position.)
 - b) Remove the tuning panel cover plate; the user ROM will be visible (Figure 6-3-7).
 - c) Using a small screwdriver, turn the ROM socket lock counterclockwise until it stops.
 - d) Hold the ROM in the fingers and pull it out of the socket, taking care not to deform the pins. (Figure 6-3-8.)

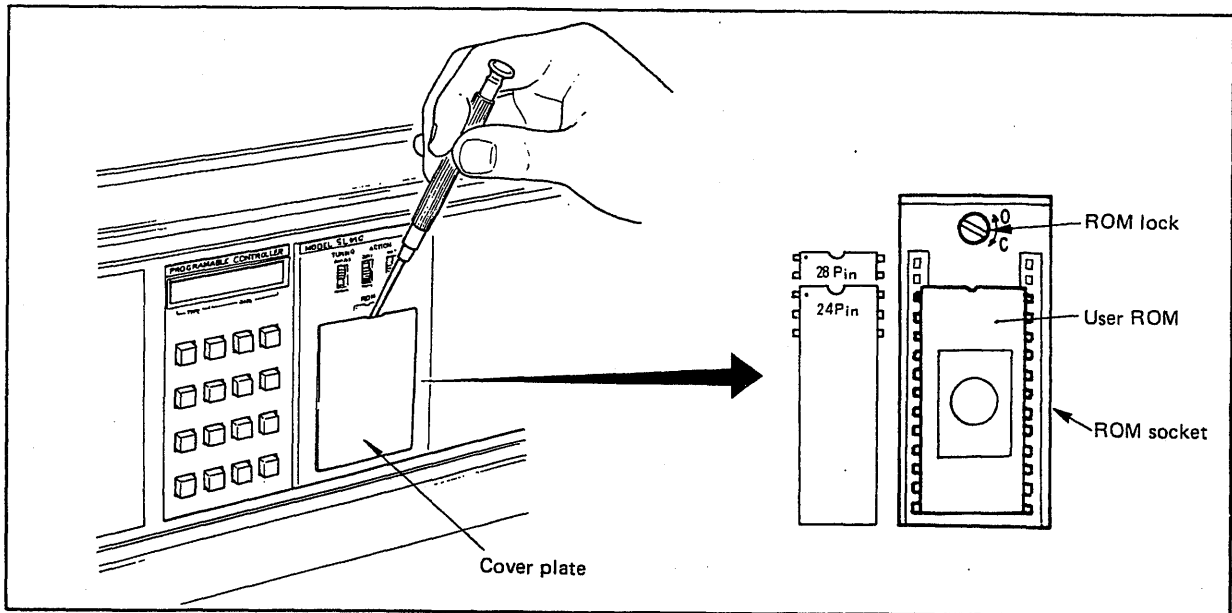

Figure 6-3-7. Removing Tuning Panel Cover Plate and ROM.

(2) Installing user ROM.

- a) Turn off the power to the instrument. (Leave the backup battery in position.)
- b) Install the ROM with the notched end up.
- c) Make sure that the ROM pins are correctly aligned with their sockets. When the 24-pin ROM is installed, connect it below the four-pin socket (two pins on each side) on top of the socket (see Figure 6-3-7).
- d) Press the ROM carefully into position.
- e) Using a small screwdriver, turn the ROM socket lock clockwise until it stops.

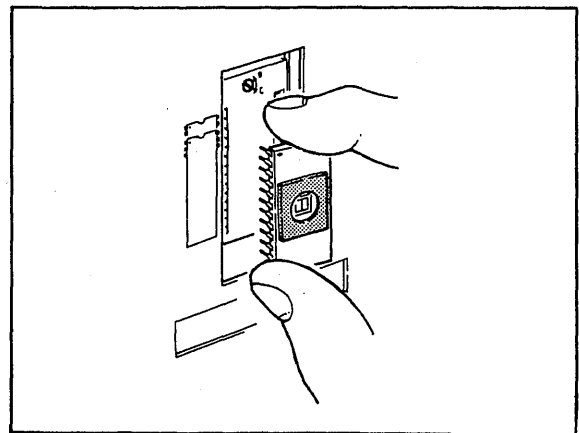

Figure 6-3-8. Removing ROM.

6-3-6. Replacing Fluorescent Tube

The brightness of the fluorescent tube decreases with the time over when it is used.

The right side panel adjustment (see Figure 6-2-5) permits the fluorescent bar graph brightness adjustment. If the adjustment cannot be made, replace the fluorescent tube (Display Board Assembly - see PL 1B4C3-01E).

It is recommended that the fluorescent tube be replaced at least every five years.

7. TROUBLESHOOTING.

If operational troubles occur in the SLMC Programmable Indicating Controller, identify the problems fully and resolve them according to the troubleshooting flowcharts shown in Section 7-1.

Troubleshooting can be facilitated by the use of the extension cable contained in the service kit (SSKD).

When the trouble is difficult to locate, consult the YOKOGAWA service station serving your area.

7-1. Troubleshooting Flowcharts.

(1) Problem Identification

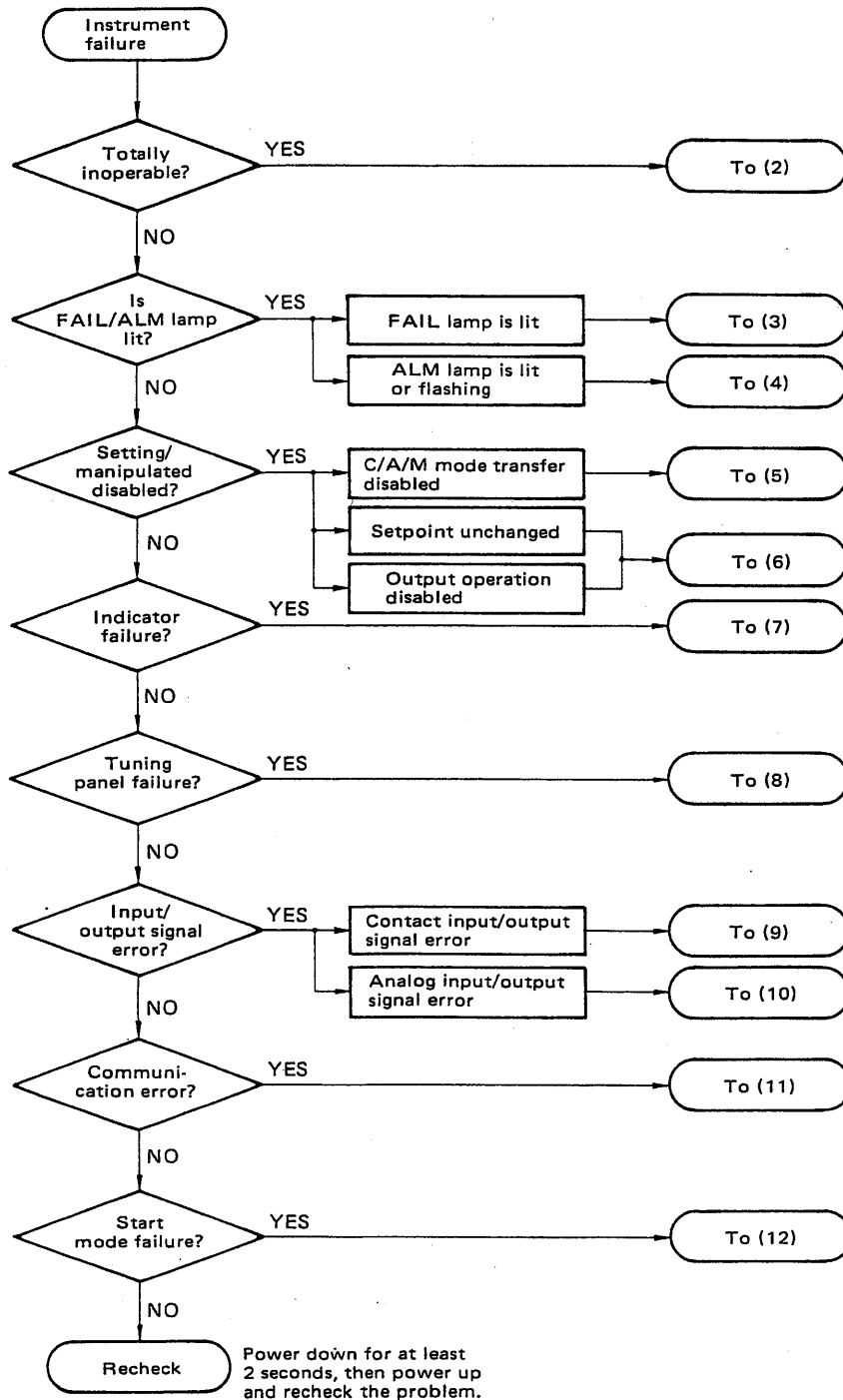

(2) Totally Inoperable

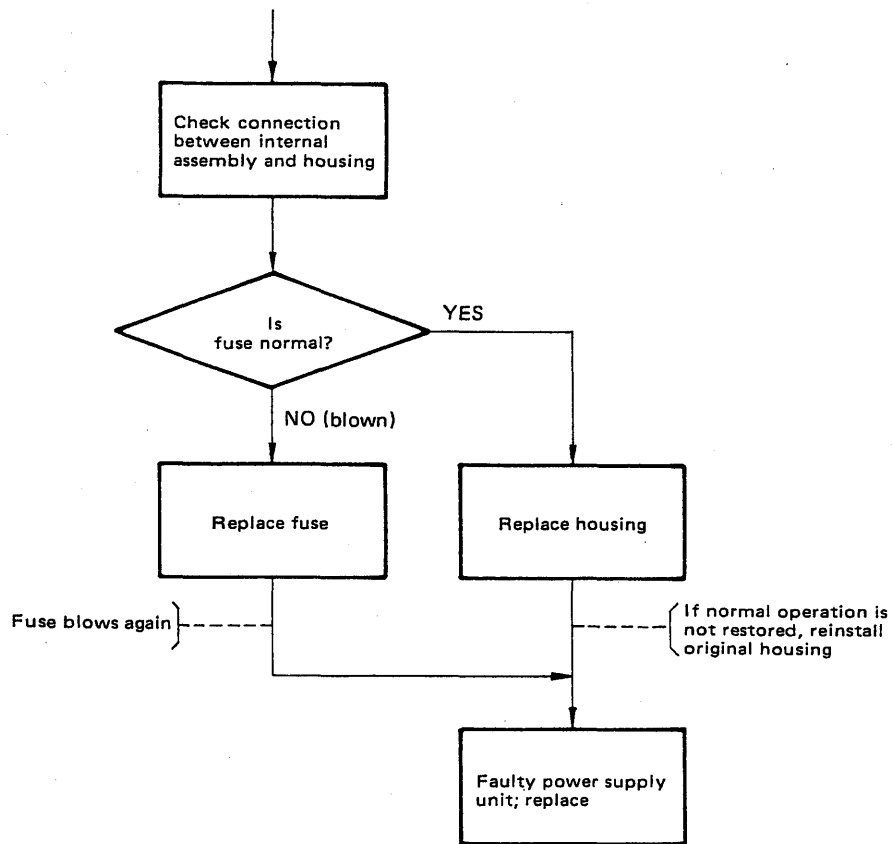

(3) FAIL Lamp is Lit

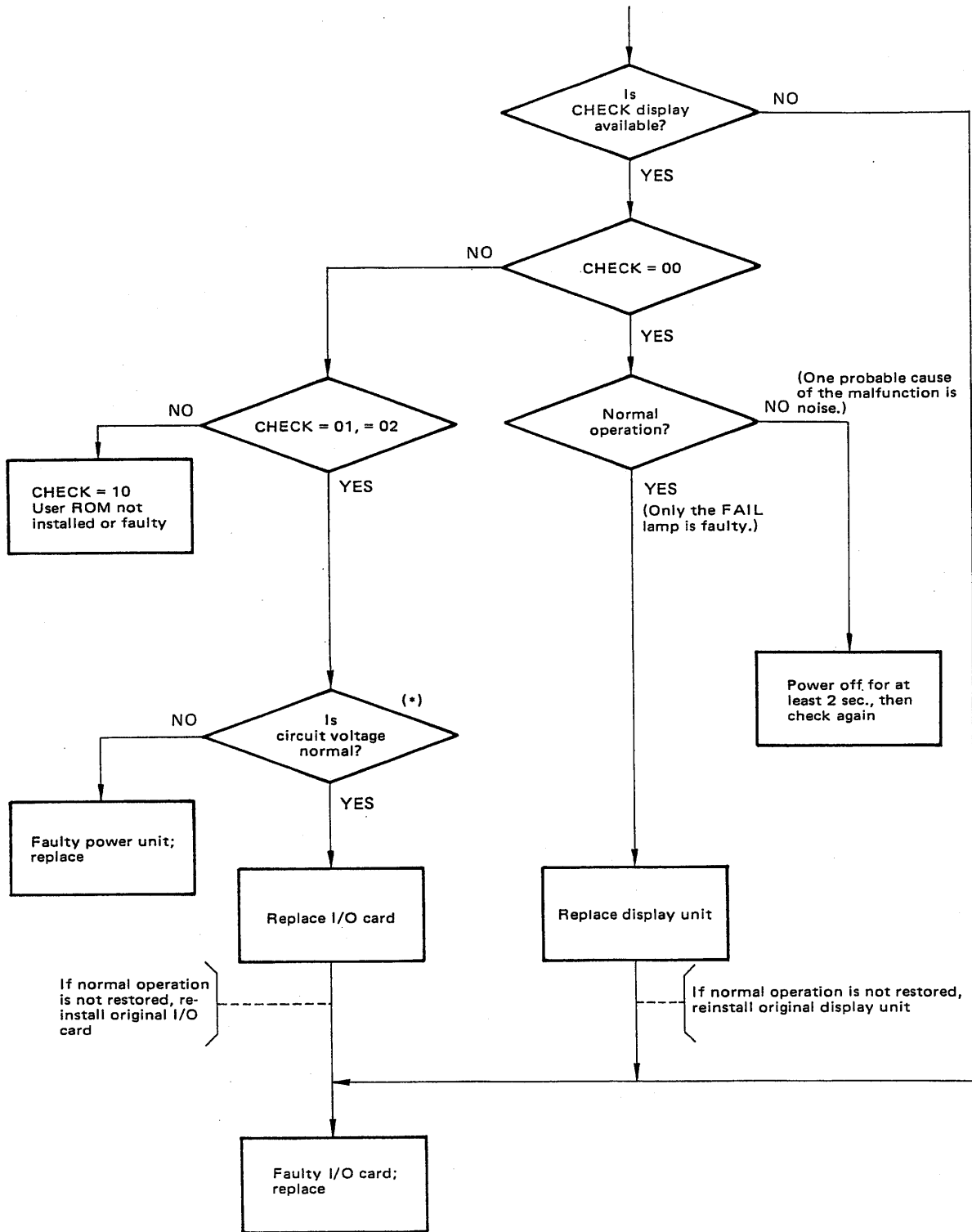

* Check to see that the voltage across User ROM pins 12 and 24 is in range 4.8 to 5.2 V.

(4) ALM Lamp is Lit or Flashing

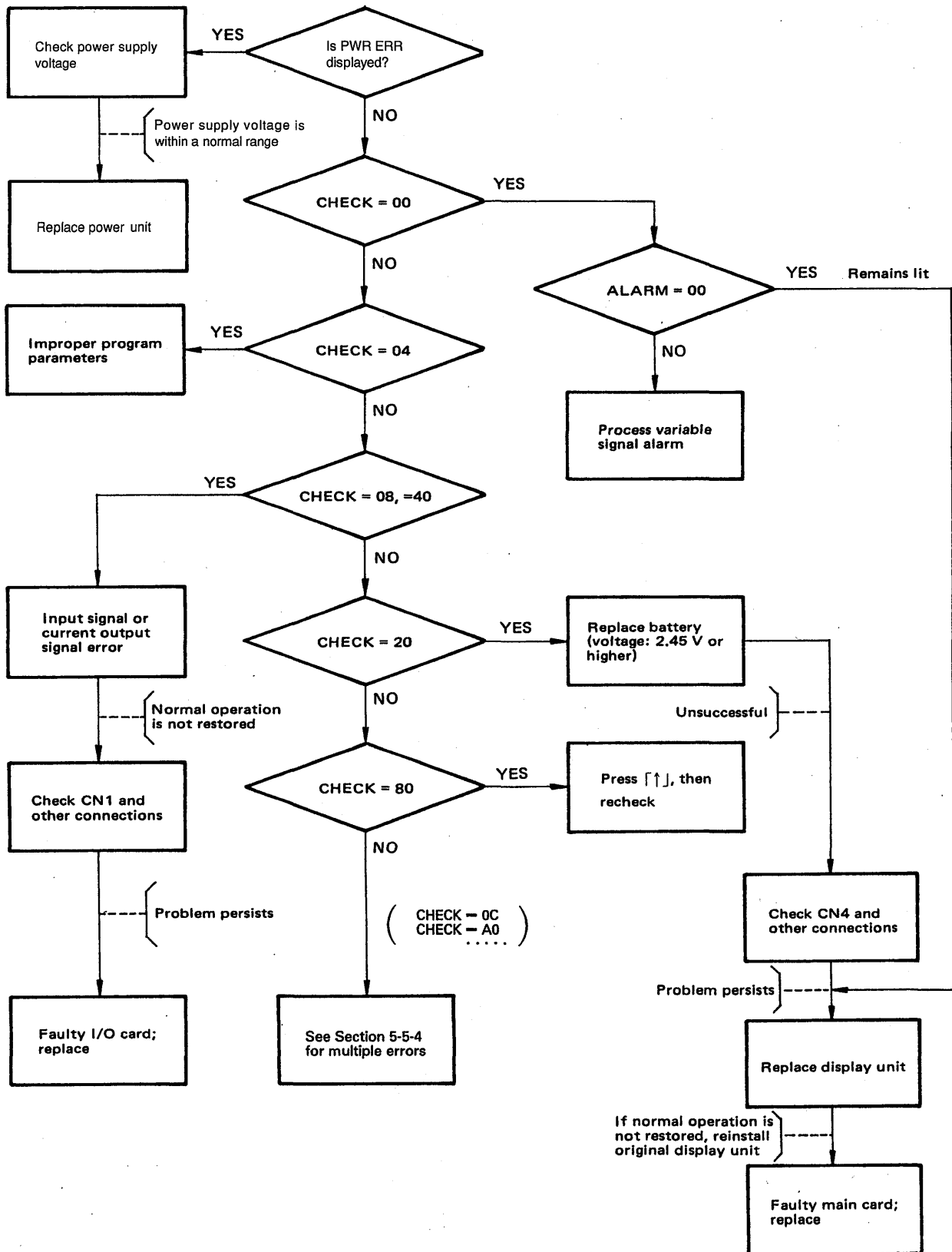

(5) C/A/M Mode Transfer Disabled

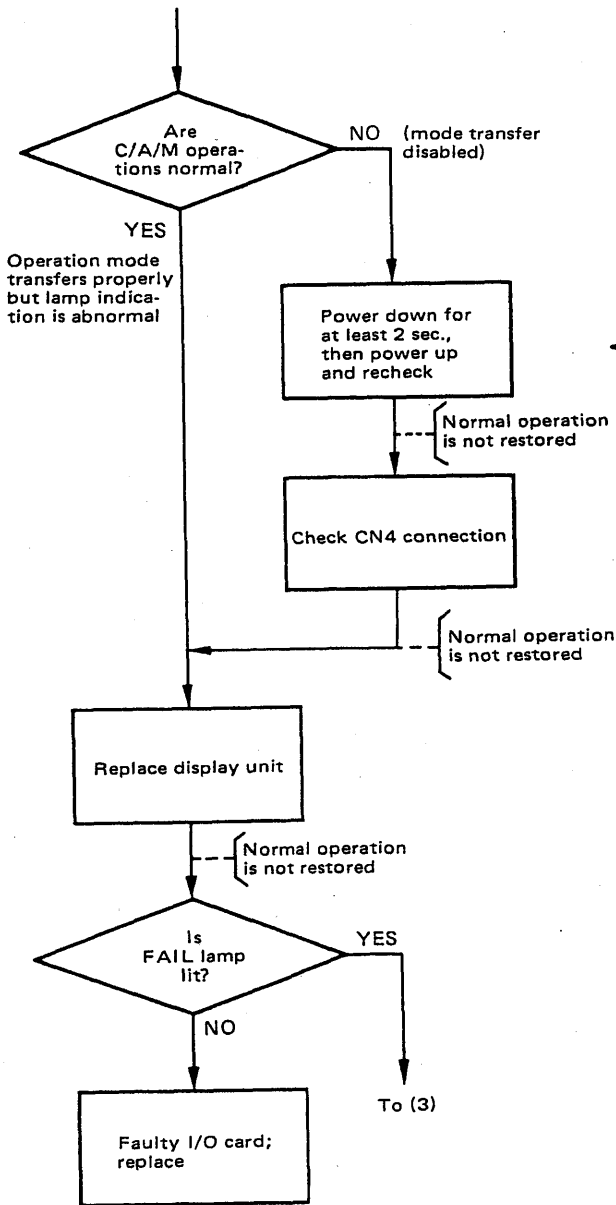

(6) Setpoint or Manipulated Output Unchanged

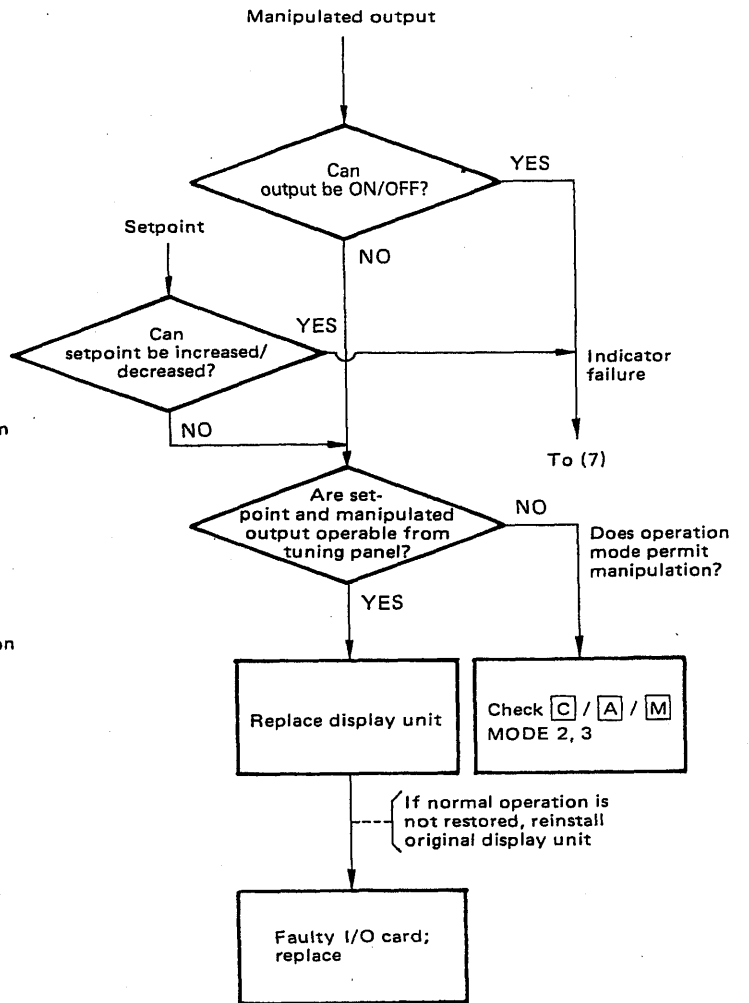

(7) Measurement Pointer/Setpoint Index Error

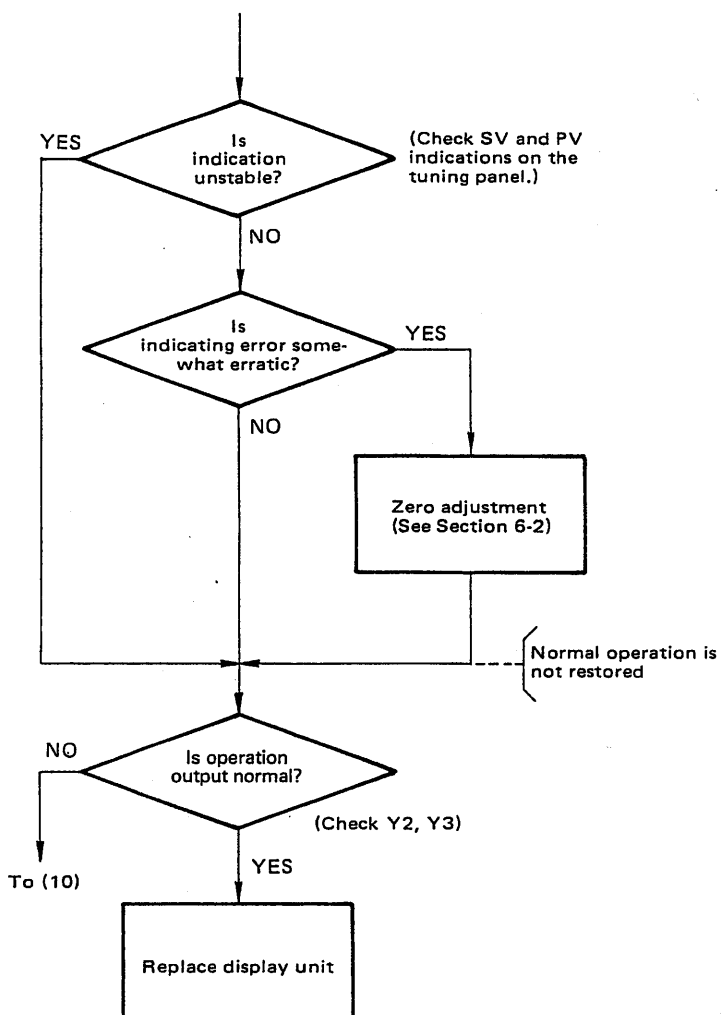

(8) Tuning panel failure

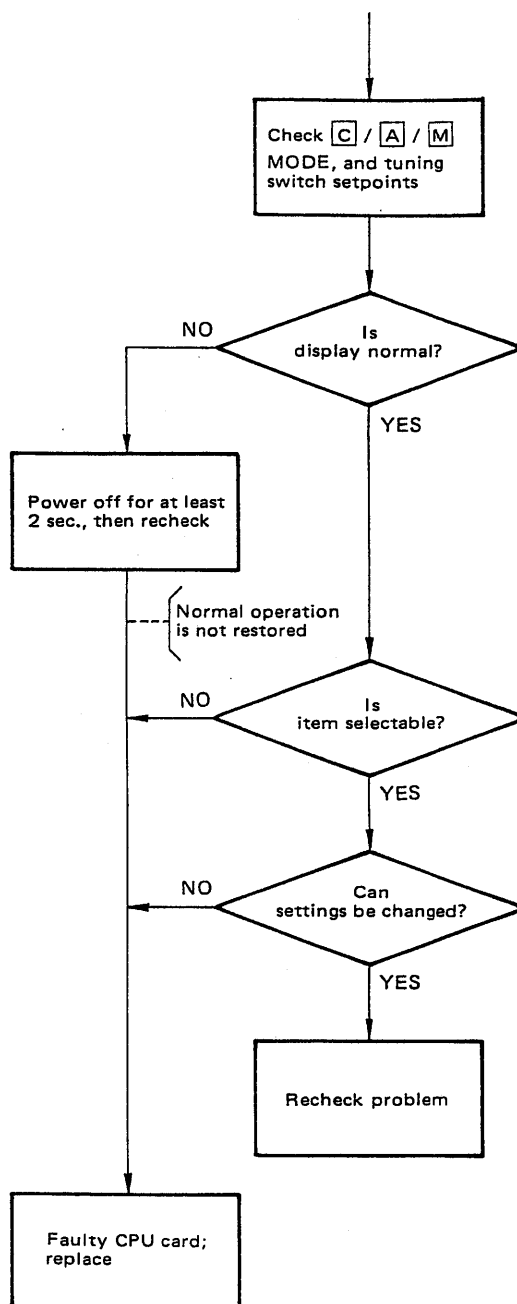

(9) Contact Input/Output Signal Error

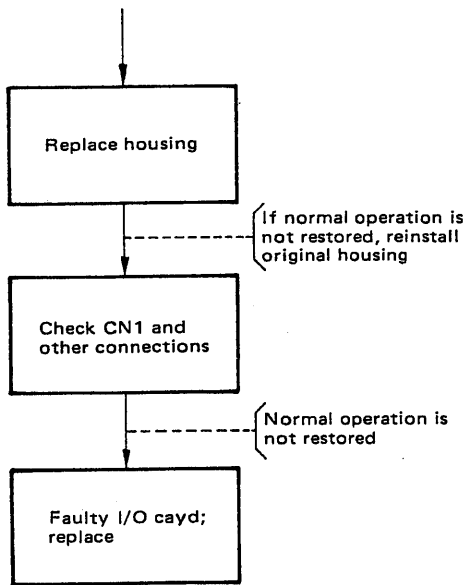

(10) Analog Input/Output Signal Error

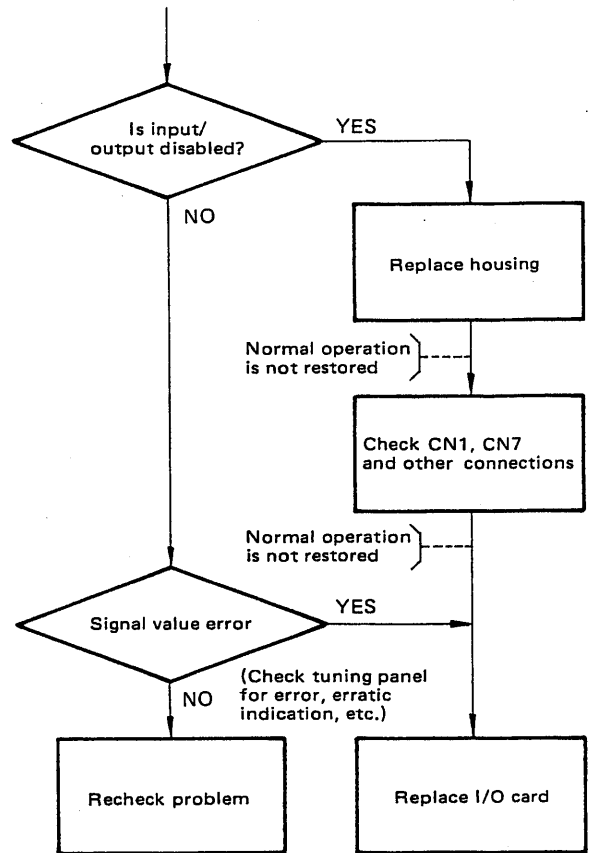

(11) Communications Failure

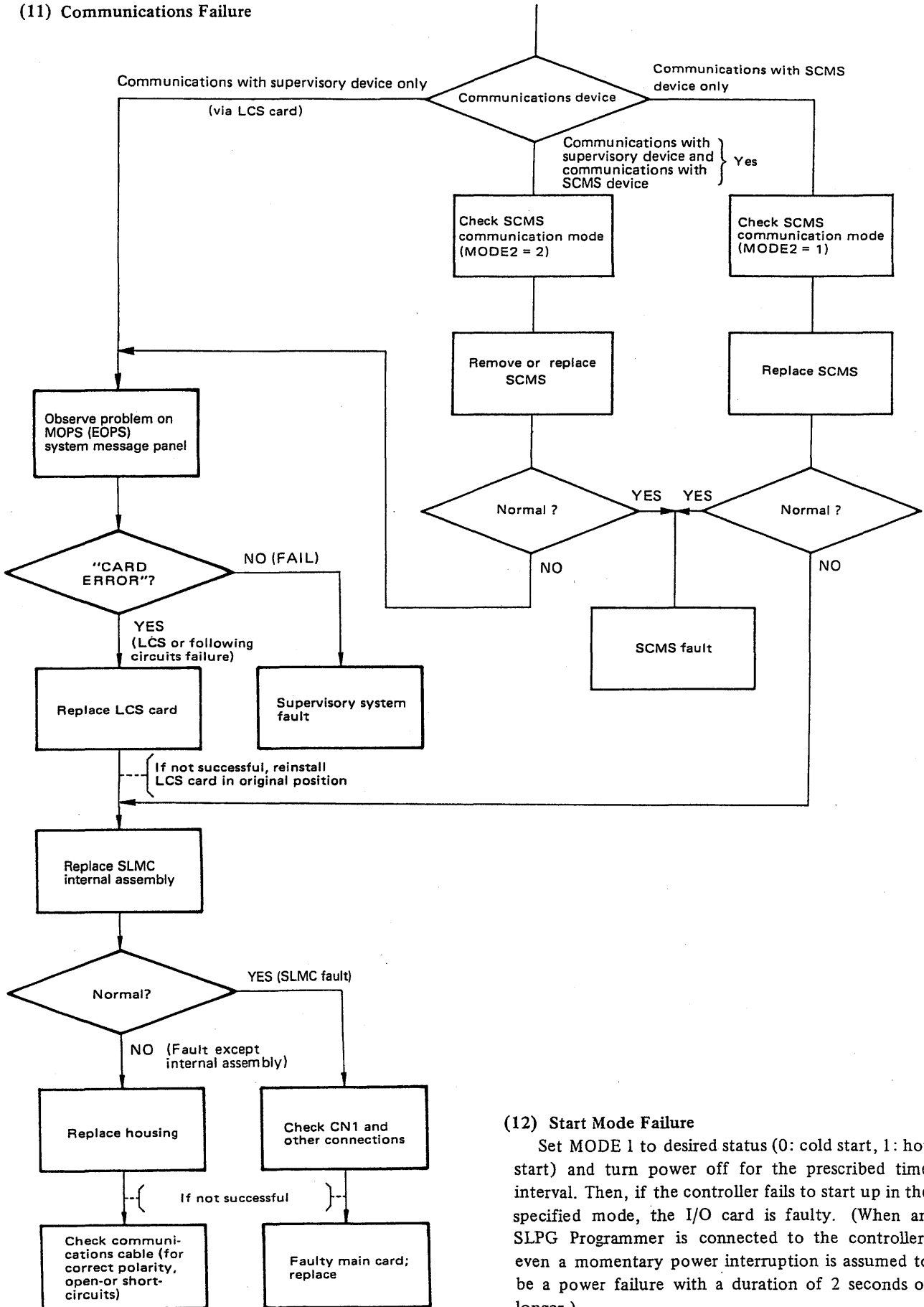

(12) Start Mode Failure

Set MODE 1 to desired status (0: cold start, 1: hot start) and turn power off for the prescribed time interval. Then, if the controller fails to start up in the specified mode, the I/O card is faulty. (When an SLPG Programmer is connected to the controller, even a momentary power interruption is assumed to be a power failure with a duration of 2 seconds or longer.)

7-2. Disassembling and Reassembling Procedures.

Follow the disassembly and reassembly procedures in this section to replace possibly faulty units.

CAUTION

Limit the scope of disassembly to the minimum required. Have the YOKOGAWA service station replace parts not covered in this section.

Initially, remove the cover as shown in Figure 7-2-1.

7-2-1. Removal of Meter Assembly.

- (1) Remove seven screws ② in Figure 7-2-3.
- (2) Remove connectors 3 (CN3, CN4 and CN7).
- (3) Carefully pull the meter assembly out toward the front.

7-2-2. Disassembling the Meter Assembly.

- (1) Extract knob ④ in Figure 7-2-3.
- (2) Remove four screws ⑤ to separate the front frame.
- (3) Pull the A/M unit out downward after removing two screws ① in Figure 7-2-2.
- (4) To separate the meter assembly, remove three screws ③ from the molded section. (The meter assembly in the fluorescent bar graph version can be separated in the same manner.)

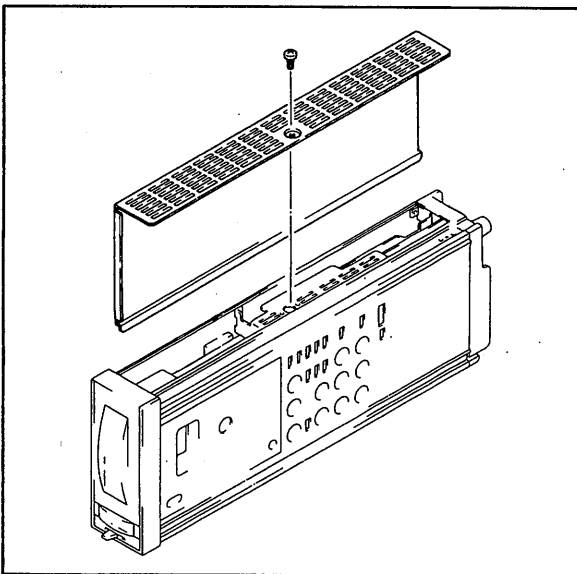

Figure 7-2-1. Removing Cover.

7-2-3. Removal of Power Supply Unit.

- (1) Remove four screws ① in Figure 7-2-3.
- (2) To separate the power supply unit, pull it out toward the rear and remove connector CN2.

7-2-4. Disassembling the Control Assembly.

- (1) Remove the meter assembly and the power supply unit as instructed in Sections 7-2-1 and 7-2-3.
- (2) Separate the I/O board assembly from the chassis by removing two screws ⑥ in Figure 7-2-3.
- (3) Remove two screws ⑦ and open the cover to expose screw ⑧ (on opposite side in the figure).
- (4) Remove two screws ⑧ from the opposite side to open the tuning panel (CPU board assembly).
- (5) Pull out the connectors CN5 and CN6 downward to separate the tuning panel (CPU board assembly).
- (6) To release the tuning panel from the bracket, remove three screws ①.

Ensure that all necessary connectors (CN1 to CN7) have been inserted in proper positions.

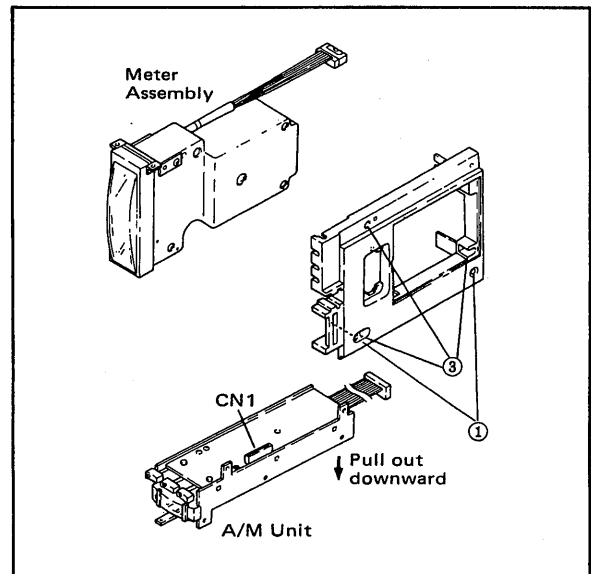

Figure 7-2-2. Disassembling Display Unit.

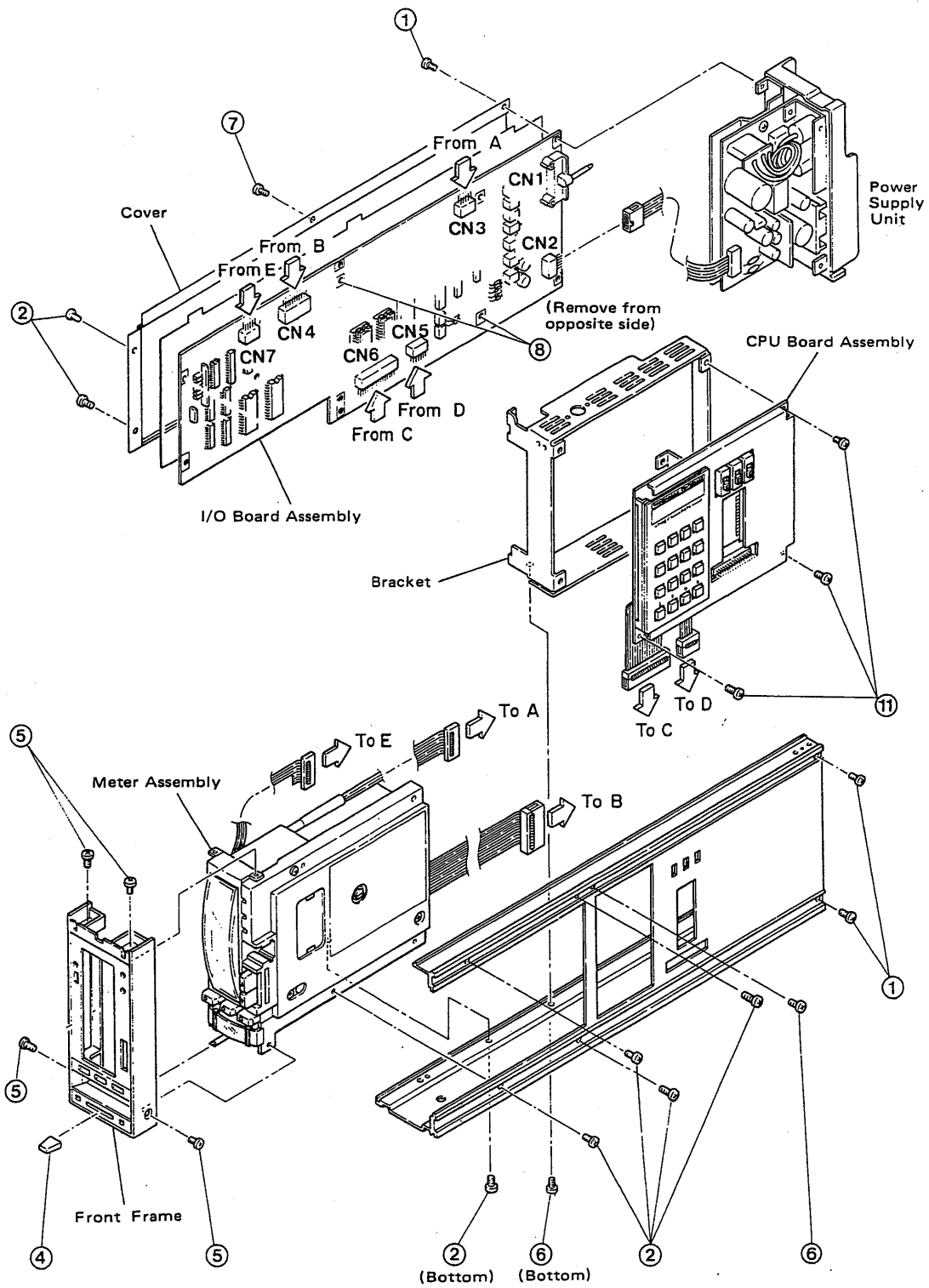

Figure 7-2-3. Disassembling Main Unit.

7-2-5. Replacement of Fluorescent Bar Graph Display Tube.

- (1) Disassemble the display assembly as instructed in Sections 7-2-1 and 7-2-2.
- (2) Remove the cover by unscrewing two screws ① in Figure 7-2-4 to expose the display tube.
- (3) Carefully pull the display tube out forward with card by grasping its PC board.
- (4) Install a new display tube and assemble it by reversing the removal procedures above. Take care not to damage the sealed part of the tube during assembly. (See Figure 7-2-4.)

7-2-6. Reassembling.

To reassemble with new parts, reverse the disassembly procedures.

Assembly Notes

- All screws are of common make.
- Ensure that all necessary connectors (CN1 to CN7) have been inserted in proper positions.
- In inserting connectors, observe their positions and faces (with bosses, visible) and opposite sides (PC board sides).

7-2-7. Continuity Check.

Once the SLMC Indicating Controller is disassembled, it is initialized with its internal data being lost. At the same time the ALM lamp lights if the controller is conducting.

As CHECK = 80 is displayed on the tuning panel, press the key and enter data into the controller again.

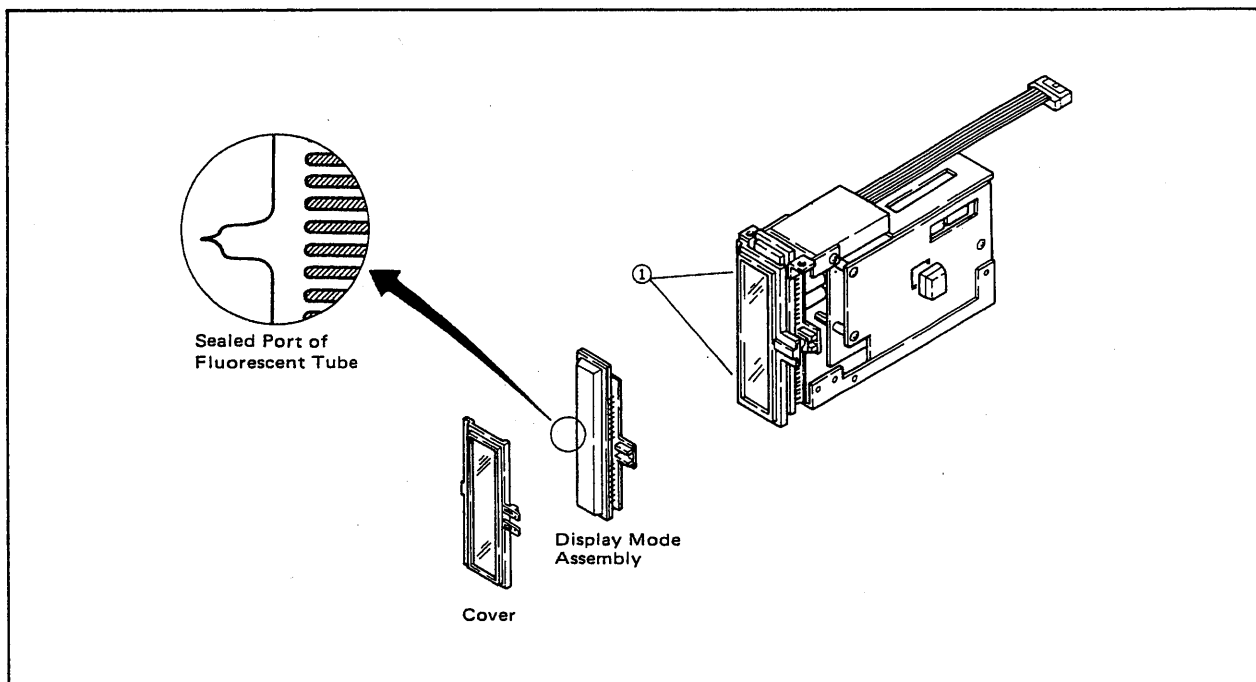
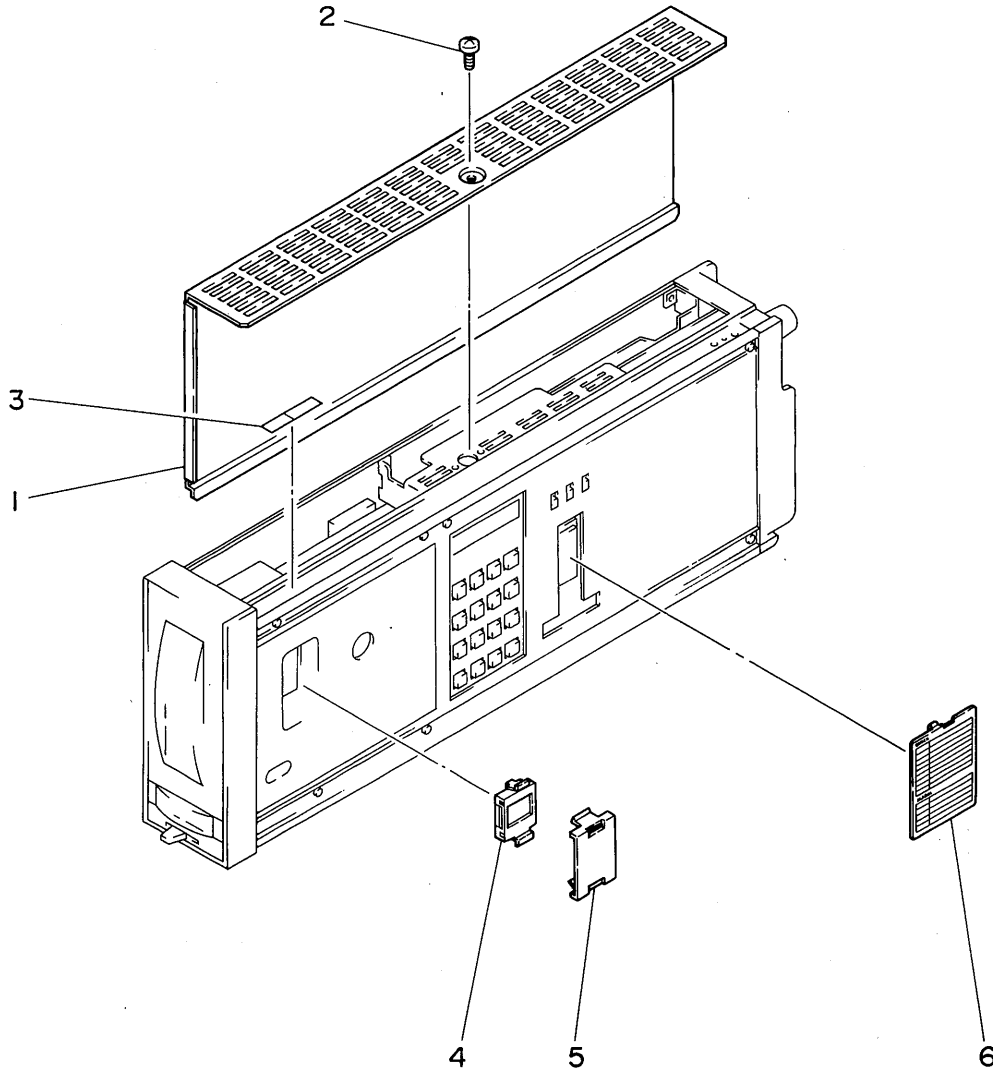

Figure 7-2-4. Replacing Fluorescent Bar Graph Display Tube.

Customer Maintenance Parts List

Model SLMC (Style E)
Programmable Indicating Controller
with Pulse Width Output

YEW SERIES 80



Item	Part No.	Qty	Description
1	E9711TG	1	Cover
2	Y9405LB	1	B.H. Screw, M4 x 5
3	Y9422NP	1	Tag No. Label (blank)
4	E9711DH	1	Battery Assembly
5	E9711GQ	1	Cover
6	E9712BE	1	Cover

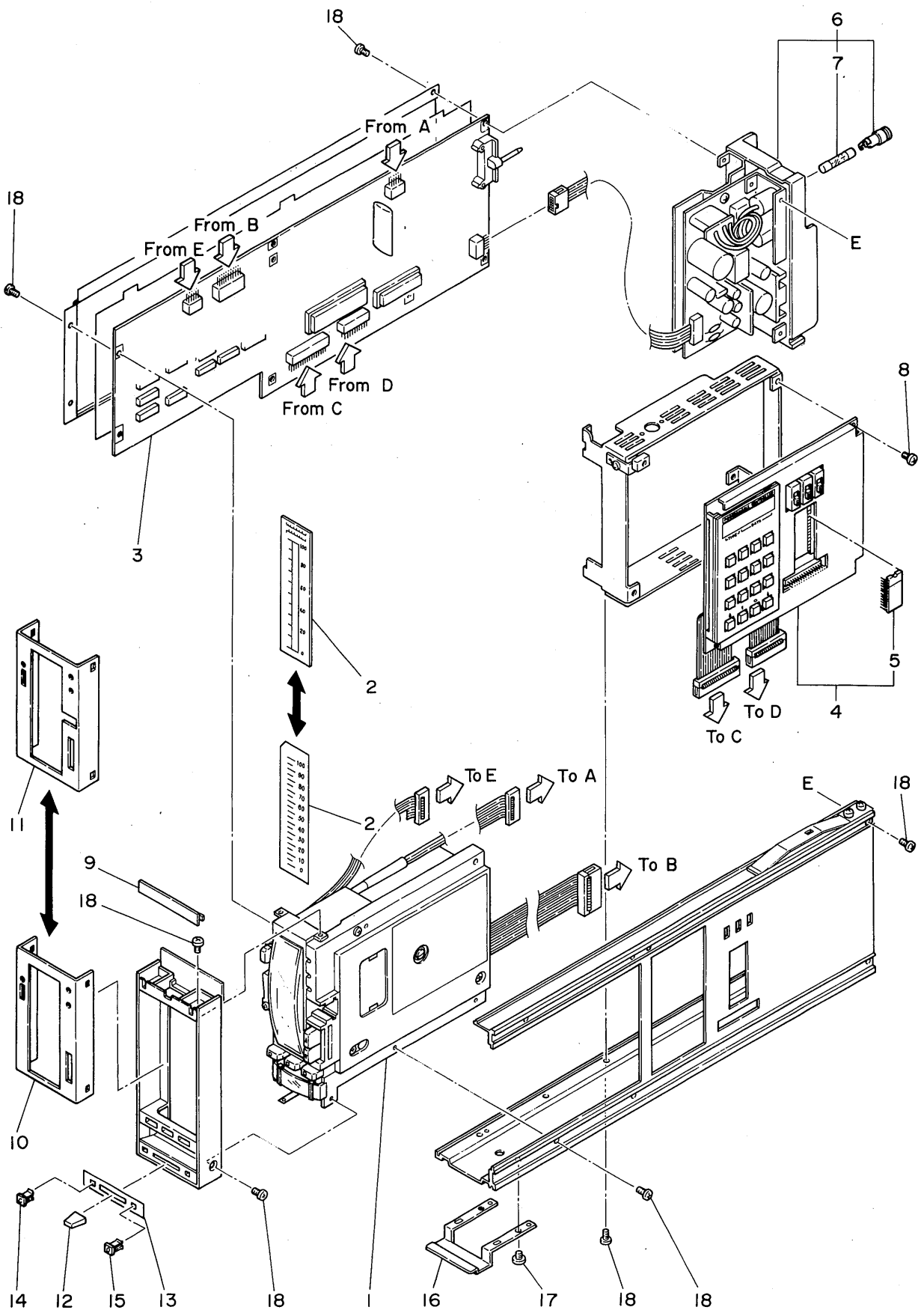

Item	Part No.	Qty		Description
		Model		
		SLMC-140	SLMC-240	
1	E9714AA	1	1	Meter Assembly
	E9714AC		1	Display Assembly
				} See Page 4
2	—	1	1	Scale (specify range when ordering)
—	—	1	1	Control Assembly
3	E9714LB	1	1	I/O Board Assembly
4	E9714FB	1	1	CPU Board Assembly
5	G9003LT	1	1	EP Rom
6	Below	1	1	Power Supply Unit
	E9716YB			For 100 V Version
	E9716YS			For 220 V Version
7	S9510VK	1	1	Fuse — "1A/250 V"
8	Y9306JB	9	9	Pan H. Screw, M3 x 6
9	E9711FG	1	1	Plate (blank)
10	E9714BE	1		Bracket
11	E9714BF		1	Bracket
12	E9711KA	1	1	Knob
13	E9711KE	1	1	Plate
14	E9711KC	1	1	Tip — "C"
15	E9711KD	1	1	Tip — "O"
16	E9711TD	1	1	Stopper
17	E9711TE	2	2	Screw
18	Y9306JB	14	14	Pan H. Screw, M3 x 6

**E9714AA Meter Assembly
E9714AC Display Assembly**

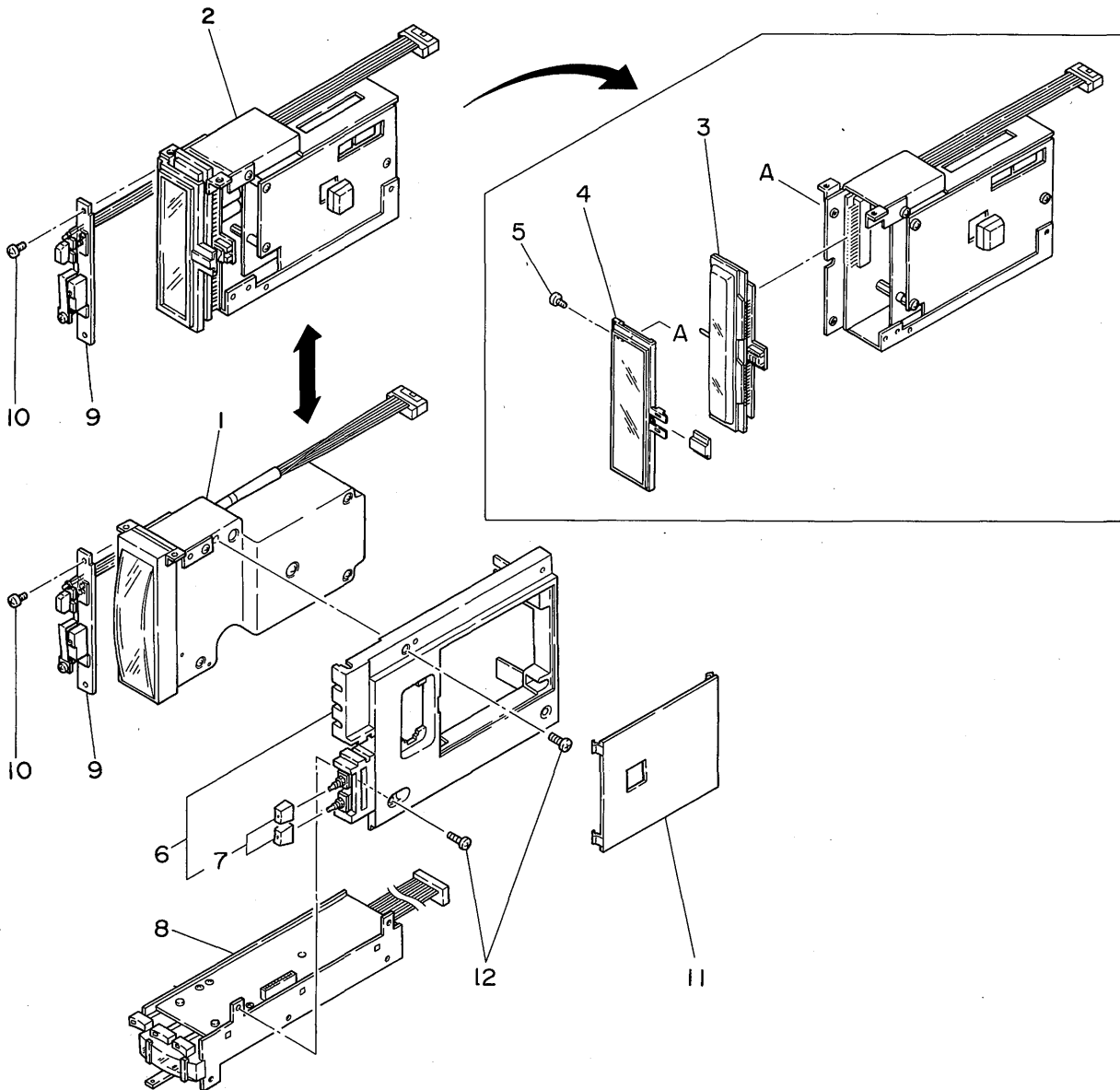

Item	Part No.	Qty		Description
		E9714AA	E9714AC	
1	E9714AB	1		Meter Assembly
2	E9714AD	1		Display Assembly
3	E9716WN	1		Display Board Assembly
4	E9711FR	1		Cover
5	Y9306JB	2		Pan H. Screw, M3 x 6
6	E9711DA	1	1	Frame Assembly
7	E9711FH	2	2	Knob
8	E9811KM	1	1	A/M Unit
9	E9714CW	1	1	PF Key Assembly
10	Y9306JB	2	2	Pan H. Screw, M3 x 6
11	E9711GP	1		Cover
12	Y9306JB	5	5	Pan H. Screw, M3 x 6

Instruction Manual

/ HTB Power Supply Terminal Connections for Panel - mounted Instruments (Option)

1. GENERAL.

If you specify the terminal board to which the power source is directly connected (suffix code / HTB), the external wiring to the terminal board is necessary.

2. APPLICABLE INSTRUMENTS.

Model	Description
SRVD	Strip Chart Recorder
SIHM	Indicator (With Housing)
SIHF	Bar Graph Indicator (With Alarms)
SIHK	Indicator (With Alarms)
SLCD	Indicating Controller
SLPC	Programmable Indicating Controller
SLMC	Programmable Indicating Controller with Pulse → Width Output
SMLD	Manual Station
SMST	Auto / Manual Station
SMRT	Ratio Set Station
SCMS	Programmable Computing Station
SBSD	Batch Set Station
SLCC	Blending Controller
SLBC	Batch Controller
STLD	Totalizer

3. NAME OF COMPONENTS AND TERMINAL DESIGNATION OF POWER SUPPLY

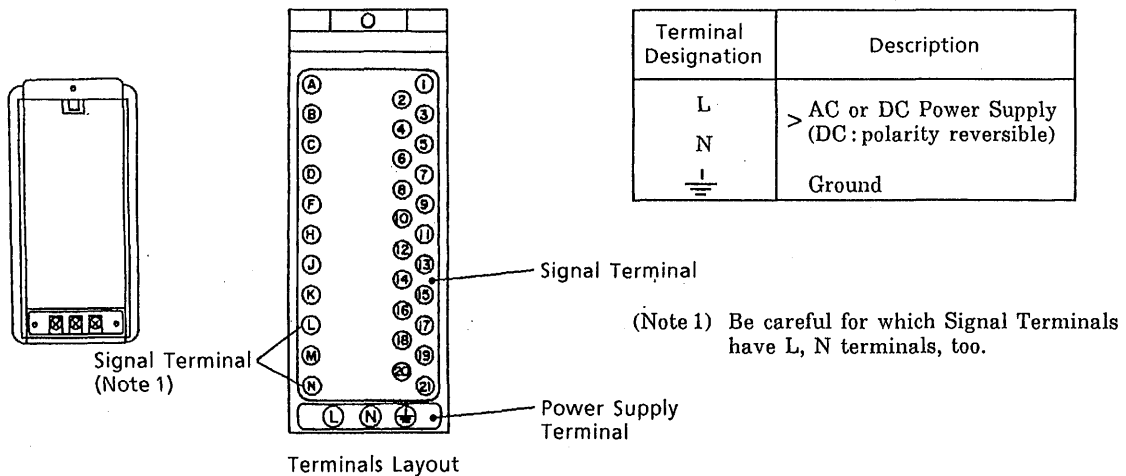

4. POWER SUPPLY AND GROUND WIRING.

- (1) All cable ends must be furnished with crimp-on type solderless lugs (for 4mm screw).
- (2) Examples of applicable cables.

Cross-sectional area of the cable conductor : 2.0mm².*

Note* : Power supply cables should be determined from the instrument power consumption - they must have conductors with cross-sectional area of at least 1.25mm².

Applicable cable : 600V vinyl insulated cable (IV), conforming to JIS C3307.

Vinyl sheathed cables for electric appliances (KIV), conforming to JIS C3316.

- (3) After completing the power supply and ground wiring, mount the power terminal cover.